

Agilent 81630B/4B/6B
Power Sensor Modules
and Agilent 81635A
Dual Power Sensor Module
User's Guide

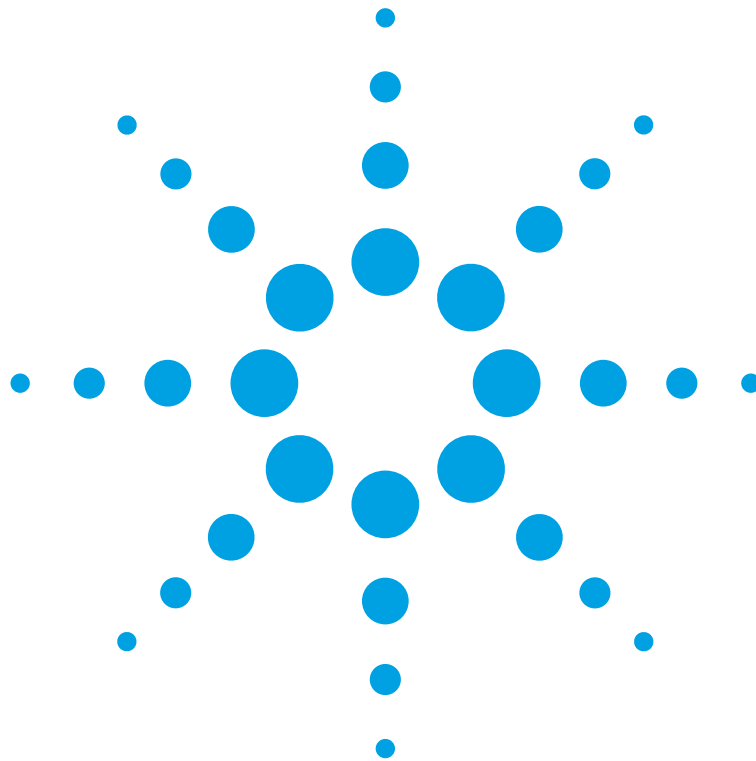

Notices

© Agilent Technologies, Inc. 2000-2005

This document contains proprietary information that is protected by copyright. All rights are reserved.

No part of this document may be reproduced in (including electronic storage and retrieval or translation into a foreign language) without prior agreement and written consent from Agilent Technologies Deutschland GmbH as governed by United States and international copyright laws.

Agilent Technologies Deutschland GmbH
Herrenberger Str. 130
71034 Böblingen
Germany

Manual Part Number

81635-90B12

Edition

Third Edition, July 2005

Second Edition, January 2002

First Edition, July 2001

Subject Matter

The material in this document is subject to change without notice.

Agilent Technologies *makes no warranty of any kind with regard to this printed material, including, but not limited to, the implied warranties of merchantability and fitness for a particular purpose.*

Agilent Technologies shall not be liable for errors contained herein or for incidental or consequential damages in connection with the furnishing, performance, or use of this material.

Printing History

New editions are complete revisions of the guide reflecting alterations in the functionality of the instrument. Updates are occasionally made to the guide between editions. The date on

the title page changes when an updated guide is published. To find out the current revision of the guide, or to purchase an updated guide, contact your Agilent Technologies representative.

Control Serial Number: First Edition applies directly to all instruments.

Warranty

This Agilent Technologies instrument product is warranted against defects in material and workmanship for a period of one year from date of shipment. During the warranty period, Agilent will, at its option, either repair or replace products that prove to be defective.

For warranty service or repair, this product must be returned to a service facility designated by Agilent. Buyer shall prepay shipping charges to Agilent and Agilent shall pay shipping charges to return the product to Buyer. However, Buyer shall pay all shipping charges, duties, and taxes for products returned to Agilent from another country.

Agilent warrants that its software and firmware designated by Agilent for use with an instrument will execute its programming instructions when properly installed on that instrument. Agilent does not warrant that the operation of the instrument, software, or firmware will be uninterrupted or error free.

Limitation of Warranty

The foregoing warranty shall not apply to defects resulting from improper or inadequate maintenance by Buyer, Buyer-supplied software or interfacing, unauthorized modification or misuse, operation outside of the environmental specifications for the product, or improper site preparation or maintenance.

No other warranty is expressed or implied. Agilent Technologies specifically disclaims the implied warranties of Merchantability and Fitness for a Particular Purpose.

Exclusive Remedies

The remedies provided herein are Buyer's sole and exclusive remedies. Agilent Technologies shall not be liable for any direct, indirect, special, incidental, or consequential damages whether based on contract, tort, or any other legal theory.

Assistance

Product maintenance agreements and other customer assistance agreements are available for Agilent Technologies products. For any assistance contact your nearest Agilent Technologies Sales and Service Office.

Certification

Agilent Technologies Inc. certifies that this product met its published specifications at the time of shipment from the factory.

Agilent Technologies further certifies that its calibration measurements are traceable to the United States National Institute of Standards and Technology, NIST (formerly the United States National Bureau of Standards, NBS) to the extent allowed by the Institutes' calibration facility, and to the calibration facilities of other International Standards Organization members.

ISO 9001 Certification

Produced to ISO 9001 international quality system standard as part of our objective of continually increasing customer satisfaction through improved process control.

Agilent Technologies Sales and Service Offices

For more information about Agilent Technologies test and measurement products, applications, services, and for a current sales office listing, visit our web site:

<http://www.agilent.com/comms/lightwave>

You can also contact one of the following centers and ask for a test and measurement sales representative.

United States:	1 800 829 4444 1 800 829 4433 (FAX)
Canada:	1 877 894 4414 1 800 746 4866 (FAX)
Europe:	+31 20 547 2111 +31 20 547 2190 (FAX)
Japan:	120 421 345 120 421 678 (FAX)
Mexico	(52 55) 5081 9469 (52 55) 5081 9467 (FAX)
Australia:	800 629 485 800 142 134 (FAX)
Asia-Pacific:	+852 800 930 871 +852 800 908 476(FAX)
Latin America	+55 11 4197 3600 +55 11 4197 3800 (FAX)

Table of Contents

Getting Started with Power Sensor Modules	9
Safety Considerations	10
Safety Symbols	10
Initial Inspection	11
Line Power Requirements	11
Operating Environment	11
Storage and Shipment	11
Environmental Information	12
What is a Power Sensor Module	13
A Description of the Front Panel	13
Analog Output	14
Optical Input	14
Accessories	15
Modules and Options	16
Connector Interfaces	17
Bare Fiber Adapters	17
Specifications	19
Definition of Terms	20
Averaging Time	20
Linearity	21
Linewidth	21
Noise	22
Power range	22
Reference conditions	22
Relative uncertainty (spectral ripple) due to interference	23
Relative uncertainty due to polarization	23
Return loss:	23
Spectral width of optical source	24
Total uncertainty	24
Uncertainty at reference conditions	24



Wavelength Range	24
Power Sensor Specifications (Autorange Mode)	25
Agilent 81635A & 81634B Specification	25
Agilent 81636B & 81637B Specification	27
Agilent 81630B Specification	29
Supplementary Performance Characteristics	31
Analog Output	31

Performance Tests 33

Equipment Required	34
Test Record	35
Test Failure	35
Instrument Specification	35
Performance Test Procedures	36
Accuracy Test	37
Test Setup	37
Linearity Test	39
Test Setup	39
+10 dBm Range	41
0 dBm Range	41
-10 dBm Range	42
-20 dBm Range	42
-30 dBm Range	43
Change Setup	43
-40 dBm Range	43
-50 dBm Range	44
Calculation	44
Example: Measurement Results	45
Calculations	46
Noise Test	48
Return Loss Test	49
Relative Uncertainty due to Polarization (Optional Test)	51
Relative Uncertainty due to Interference (Optional Test)	53
Test Record Sheets	56

Cleaning Instructions	75
<hr/>	
Safety Precautions	76
Why is it important to clean optical devices ?	77
What do I need for proper cleaning?	78
Standard Cleaning Equipment	78
Dust and shutter caps	78
Isopropyl alcohol.....	79
Cotton swabs.....	79
Soft tissues	79
Pipe cleaner	80
Compressed air	80
Additional Cleaning Equipment	81
Microscope with a magnification range about 50X up to 300X.....	81
Ultrasonic bath	81
Warm water and liquid soap	82
Premoistened cleaning wipes.....	82
Polymer film	82
Infrared Sensor Card.....	82
Preserving Connectors	83
Cleaning Instrument Housings	84
Which Cleaning Procedure should I use ?	84
How to clean connectors	85
How to clean connector interfaces	87
How to clean bare fiber adapters	88
How to clean lenses	89
How to clean instruments with a fixed connector interface	90
How to clean instruments with a recessed lens interface	91
How to clean optical devices which are sensitive to mechanical stress and pressure	92
Additional Cleaning Information	93
How to clean bare fiber ends	93
How to clean large area lenses and mirrors	94
Other Cleaning Hints	96
Index	97
<hr/>	



1

Getting Started with Power Sensor Modules

This chapter introduces the features of the Agilent 81630B/4B/6B Power Sensor Modules and the 81635A Dual Power Sensor Module.

Safety Considerations	10
Safety Symbols	10
Initial Inspection	11
Line Power Requirements	11
Operating Environment	11
Storage and Shipment	11
Environmental Information	12
What is a Power Sensor Module	13
A Description of the Front Panel	13
Analog Output	14
Optical Input	14

Safety Considerations

The following general safety precautions must be observed during all phases of operation, service, and repair of this instrument. Failure to comply with these precautions or with specific warnings elsewhere in this manual violates safety standards of design, manufacture, and intended use of the instrument. Agilent Technologies Inc. assumes no liability for the customer's failure to comply with these requirements.

Before operation, review the instrument and manual, including the red safety page, for safety markings and instructions. You must follow these to ensure safe operation and to maintain the instrument in safe condition.

WARNING

The WARNING sign denotes a hazard. It calls attention to a procedure, practice or the like, which, if not correctly performed or adhered to, could result in injury or loss of life. Do not proceed beyond a WARNING sign until the indicated conditions are fully understood and met

Safety Symbols



The apparatus will be marked with this symbol when it is necessary for the user to refer to the instruction manual in order to protect the apparatus against damage.

Initial Inspection

Inspect the shipping container for damage. If there is damage to the container or cushioning, keep them until you have checked the contents of the shipment for completeness and verified the instrument both mechanically and electrically.

The Performance Tests give procedures for checking the operation of the instrument. If the contents are incomplete, mechanical damage or defect is apparent, or if an instrument does not pass the operator's checks, notify the nearest Agilent Technologies Sales/Service Office.

WARNING

To avoid hazardous electrical shock, do not perform electrical tests when there are signs of shipping damage to any portion of the outer enclosure (covers, panels, etc.).

Line Power Requirements

The Agilent 81630B/4B/6B Power Sensor Modules and Agilent 81635A Dual Power Sensor Module operate when installed in the Agilent 8163A/B Lightwave Multimeter, Agilent 8164A/B Lightwave Measurement System, and Agilent 8166A/B Lightwave Multichannel System.

Operating Environment

The safety information in the Agilent 8163A/B Lightwave Multimeter, Agilent 8164A/B Lightwave Measurement System, and Agilent 8166A/B Lightwave Multichannel System User's Guide summarizes the operating ranges for the Agilent 81630B/4B/6B Power Sensor Modules and Agilent 81635A Dual Power Sensor Module. In order for these modules to meet specifications, the operating environment must be within the limits specified for the Agilent 8163B Lightwave Multimeter, Agilent 8164B Lightwave Measurement System, and Agilent 8166B Lightwave Multichannel System.

Storage and Shipment

This module can be stored or shipped at temperatures between -40°C and $+70^{\circ}\text{C}$. Protect the module from temperature extremes that may cause condensation within it.

Environmental Information



This product complies with the WEEE Directive (2002/96/EC) marking requirements. The affixed label indicates that you must not discard this electrical/ electronic product in domestic household waste.

Product Category: With reference to the equipment types in the WEEE Directive Annex I, this product is classed as a "Monitoring and Control instrumentation" product.

Do not dispose in domestic household waste.

To return unwanted products, contact your local Agilent office, or see www.agilent.com/environment/product/ for more information.

What is a Power Sensor Module

A Power Sensor Module measures the power emitted from a connected single-mode or multi-mode fiber (with Numerical Aperture $\leq 0.24/0.3$ and core diameter up to 100 μm according to the model). The wavelength and power range depend on the sensor element.

A Description of the Front Panel

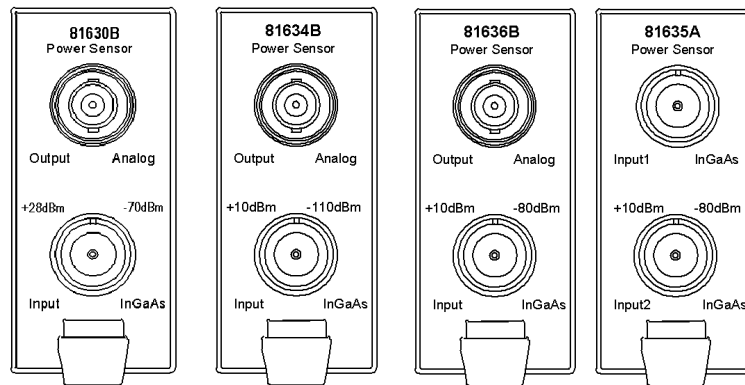

Figure 1 Front Panel of the Agilent Power Sensor Modules

Analog Output

The analog output is the BNC connector on the front of the sensor module. It outputs a voltage directly proportional to the strength of the optical signal at the optical input in the current range. The analog signal is always in the range between 0 and 2V, 2V corresponding to a full power input signal in the current range, 0V corresponding to no input signal.

During autoranging, the level to which 2V corresponds changes. You should disable autoranging when using the analog output.

Disabling Autoranging

Select the best range for the application using the mainframes user interface. Select <Menu>, <Range Mode>, <Manual> and then choose from the list of ranges.

Applications

Possible applications for the analog output are:

- to close the feedback loop controlling the current supplied to a laser
- to aid positioning the system for fiber alignment tasks
- to monitor optical power on an oscilloscope

The analog signal reacts instantaneously to the input signal, whereas the power shown on the display is subject to averaging.

Optical Input

The optical input to the sensor requires a connector interface (or bare fiber adapter) to match the connector type (or bare fiber) to the sensor. See *"Accessories"* on page 15 for details.



2

Accessories

The Agilent 81630B/4B/6B Power Sensor Module and the Agilent 81635A Dual Power Sensor Module are available in various configurations for the best possible match to the most common applications.

This chapter provides information on the available options and accessories.

Modules and Options	16
Connector Interfaces	17
Bare Fiber Adapters	17

Modules and Options

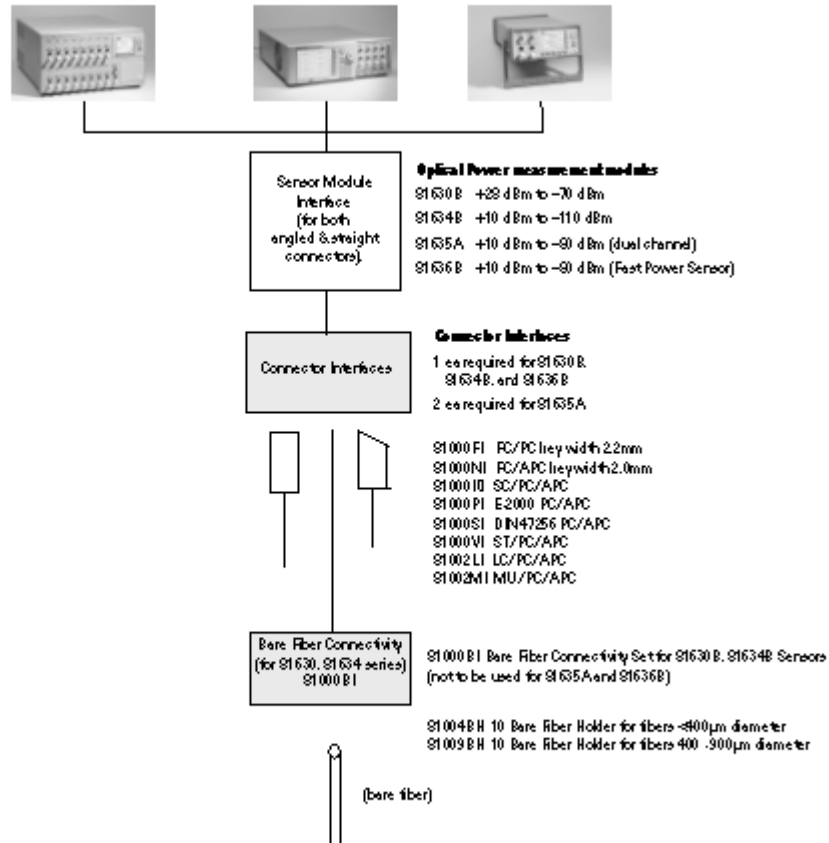

Note: All sensor inputs are non-contact and accept both straight and angled connectors.

Figure 2 Recommended Connector Interfaces and Bare Fiber Adapters

Connector Interfaces

Table 1 Connector Interfaces

Product Number	Connector Interface Type
81000FI	FC/PC/SPC
81000KI	SC/APC
81000NI	FC/APC
81000PI	E-2000
81000SI	DIN 47526
81000VI	ST
81002LI	LC

Bare Fiber Adapters

Table 2 Connector Interface and Bare Fiber Adapter Combinations

Product Number	Bare Fiber Adapter	Note
81000BI	Bare Fiber Kit for 81630B/81634B	
81004BH	Bare Fiber Holder Set	0-400 μ m
81009BH	Bare Fiber Holder Set	400-900 μ m

3

Specifications

Agilent 81630B/4B/6B Power Sensor Modules and the Agilent 81635A Dual Power Sensor Module are produced to the ISO 9001 international quality system standard as part of Agilent’s commitment to continually increasing customer satisfaction through improved quality control.

Specifications describe the modules’ and heads’ warranted performance. Supplementary performance characteristics describe the modules’ and heads’ non-warranted typical performance.

Because of the modular nature of the instrument, these performance specifications apply to these modules and heads rather than the mainframe unit.

Definition of Terms	20
Averaging Time	20
Linearity	21
Linewidth	21
Noise	22
Power range	22
Reference conditions	22
Relative uncertainty (spectral ripple) due to interference	23
Relative uncertainty due to polarization	23
Return loss:	23
Spectral width of optical source	24
Total uncertainty	24
Uncertainty at reference conditions	24
Wavelength Range	24
Power Sensor Specifications (Autorange Mode)	25
Supplementary Performance Characteristics	31
Analog Output	31

Definition of Terms

This section defines terms that are used both in this chapter and *“Performance Tests” on page 33*.

Generally, all specifications apply for the given environmental conditions and after warmup time.

Measurement principles are indicated. Alternative measurement principles of equal value are also acceptable.

Averaging Time

Time defining the period during which the power meter takes readings for averaging. At the end of the averaging time the average of the readings is available (display- or memory-update). Symbol T_{avg} .

Linearity

The linearity error is defined as the relative difference between the displayed power ratio, D_x/D_0 , and the actual (true) power ratio P_x/P_0 caused by changing the displayed power level from the reference level, D_0 , to an arbitrary displayed level, D_x . Symbol N .

if expressed in %

$$N = \left(\frac{D_x/D_0}{P_x/P_0} - 1 \right) 100$$

if expressed in dB

$$N_{dB} = 10 \log \left(\frac{D_x/D_0}{P_x/P_0} \right)$$

Conditions: reference level 10 μ W, displayed power levels within the specified range, zero less than specified time prior to measurement.

Note 1: ideally $N = 0$ %, respectively 0 dB.

Note 2: the power-dependent nonlinearity, $N(P_x)$, can alternatively be expressed by the following formula:

$$N(P_x) = \frac{r(P_x) - r(P_0)}{r(P_0)}$$

where $r(P)$ is the power-dependent responsivity (for a power meter, the responsivity is defined as the ratio of displayed power to actual input power).

Linewidth

FWHM spectral bandwidth. The 3 dB width of the optical spectrum, expressed in Hertz. Symbol: Δf .

Noise

The peak-to-peak change of displayed power level with zero input power level (dark).

Conditions: Zero prior to measurement, averaging time and observation time as specified, lowest power range selected and wavelength range as specified.

Measurement: the measurement result is obtained by:

$Noise = P_{max} - P_{min}$ expressed as peak-to-peak within the given time span. Any offset is automatically excluded this way.

Power range

The power range is defined from the highest specified input power level to the smallest input power level that causes a noticeable change of displayed power level.

Conditions: wavelength, averaging time as specified.

Reference conditions

The specified conditions during the spectral responsivity calibration, or conditions which are extrapolated from the conditions during calibration.

Conditions: power level, beam diameter or fiber type, numerical aperture, wavelength, spectral width, ambient temperature as specified, at the day of calibration. →Noise and drift observed over a specified observation time, with a temperature change of not more than $\pm\Delta T$.

Relative uncertainty (spectral ripple) due to interference

Uncertainty of power reading when using a coherent source, due to a periodic change of the power meter's responsivity caused by optical interference¹ between reflective interfaces within the power meter's optical assembly.

Conditions: constant wavelength, constant power level, angled connector as specified, linewidth of source <100 MHz, temperature as specified.

NOTE

Spectral ripple is measured by stepping the source wavelength over the wavelength range specified.

Relative uncertainty due to polarization

Also termed polarization-dependent responsivity (PDR), the relative uncertainty due to polarization is the uncertainty of the displayed power level on the input polarization state, expressed as the difference between the highest and the lowest displayed power. Uncertainty figures are based upon a 95% confidence level.

Conditions: laser source with variable polarization state, generation of all possible polarization states (covering the entire Poincaré sphere), constant wavelength, constant power level, angled connector as specified, temperature as specified.

Return loss:

The ratio of the incident power to the reflected power expressed in dB.

Symbol: RL.

$$RL = 10 \log \left(\frac{P_{in}}{P_{back}} \right)$$

Conditions: the return loss excludes any reflections from the fiber end used as radiation source.

Spectral width of optical source

Full width at half maximum. The 3 dB width of the optical spectrum, expressed in nm.

Symbol: FWHM.

Total uncertainty

The uncertainty for a specified set of operating conditions, including noise and drift.

Conditions: power level, beam diameter or fiber type, numerical aperture, wavelength, spectral width, ambient temperature, re-calibration period as specified. →Noise and drift observed over a specified observation time, with a temperature change of not more than $\pm\Delta T$.

Uncertainty at reference conditions

The uncertainty for the specified set of reference conditions, including all uncertainties in the calibration chain from the national laboratory to the test meter.

Wavelength Range

The range of wavelengths for which the power meter is calibrated.

Note: Selectable wavelength setting of the power meter for useful power measurements (operating wavelength range).

Literature

[1] ***Fiber optic test and measurement***, Hewlett Packard Professional Books, edited by Prentice Hall, ISBN 0-13-534330-5

Power Sensor Specifications (Autorange Mode)

Agilent 81635A & 81634B Specification

Table 3 Power Sensor Module Specifications

	Agilent 81635A	Agilent 81634B
Sensor Element	InGaAs (dual)	InGaAs
Wavelength Range	800-1650 nm	800 - 1700 nm
Power Range	+10 to -80 dBm	+10 to -110 dBm
Applicable Fiber Type	Standard SM and MM up to 62.5 μm core size, NA \leq 0.24	Standard SM and MM up to 100 μm core size, NA \leq 0.3
Uncertainty (accuracy) at Reference Conditions ^[1]	$\pm 3\%$ (1200 nm to 1630 nm)	$\pm 2.5\%$ (1000 nm to 1630 nm)
Total Uncertainty ^[2]	$\pm 5\% \pm 20 \text{ pW}$ ^{[8], [9]} (1200 nm to 1630 nm)	$\pm 4.5\% \pm 0.2 \text{ pW}$ (1000 nm to 1630 nm)
Relative Uncertainty Due to Polarization ^[3]	$\pm 0.015 \text{ dB}$ typical	$< \pm 0.005 \text{ dB}$
Spectral Ripple (due to interference) ^[4]	$\pm 0.015 \text{ dB}$ typical	$< \pm 0.005 \text{ dB}$
Linearity (power) ^[5] - at 23°C $\pm 5^\circ\text{C}$ - at operating temp. range	CW +10 to -60 dBm (1200 to 1630 nm) $< \pm 0.02 \text{ dB} \pm 20 \text{ pW}$ ^[9] $< \pm 0.06 \text{ dB} \pm 20 \text{ pW}$ ^[9]	CW +10 to -90 dBm (1000 to 1630 nm) $< \pm 0.015 \text{ dB} \pm 0.2 \text{ pW}$ $< \pm 0.05 \text{ dB} \pm 0.5 \text{ pW}$
Return Loss ^[7]	$> 40 \text{ dB}$	$> 55 \text{ dB}$
Noise (peak to peak) ^{[5], [6]}	$< 20 \text{ pW}$	$< 0.2 \text{ pW}$
Averaging Time (minimal)	100 μs	100 μs
Analog Output	none	included
Dimensions (H x W x D)	75 mm \times 32 mm \times 335 mm (2.8" \times 1.3" \times 13.2")	
Weight	0.5 kg	
Recalibration Period	2 years	
Operating Temperature	+10°C to +40°C	0°C to +45°C
Humidity	Non-condensing	
Warm-up time	20 minutes	

Table 3 Power Sensor Module Specifications

	Agilent 81635A	Agilent 81634B
[1] Reference Conditions	<ul style="list-style-type: none"> Power level 10 μW (-20 dBm), continuous wave (CW) Fiber 50 μm graded-index, NA=0.2 Ambient temperature 23°C \pm 5°C On day of calibration (add \pm 0.3% for ageing over one year; add \pm 0.6% over two years) Spectral width of source < 10 nm (FWHM) Wavelength setting at Power Meter must correspond to source wavelength \pm 0.4 nm 	
[2] Operating Conditions:	<ul style="list-style-type: none"> Fiber \leq 50 μm, NA \leq 0.2 Averaging Time 1s Only Agilent 81635A: For Fiber 62.5μm, graded index (NA=0.24): add \pm2% Within one year of calibration, add 0.3% for second year Add \pm1% for Biconic connector Operating temperature as specified, humidity: non-condensing 	
[3] All states of polarization at constant wavelength (1550 nm \pm 30 nm) and constant power, straight connector, T=23°C\pm5 °C	<p>For angled connector (8°) add \pm 0.01 dB typ.</p>	
[4] Conditions:	<p>Wavelength 1550 nm \pm 30 nm, fixed state of polarization, constant power, Temperature 23°C \pm 5°C</p> <p>Linewidth of source 100 MHz, angled connector 8°. Max. \pm 0.025 mdB</p>	
[5] Does not include noise		
[6] Averaging time 1 s, T = 23°C \pm 5 °C, At constant temperature ($\Delta\text{T} = \pm$ 1°C), observation time 300 s. Wavelength range 1200 - 1630 nm.		
[7] Conditions	<ul style="list-style-type: none"> Wavelengths 1310 nm \pm 30 nm and 1550 nm \pm 30 nm Standard single-mode fiber, angled connector min 8° T= 23°C \pm 5 °C 	
[8] For wavelengths >1600 nm add \pm0.06 %/nm		
[9] For input power >2 mW add \pm0.02 dB		

Agilent 81636B Specification

Table 4 Fast Optical Power Sensor Module Specifications

	Agilent 81636B
Sensor Element	InGaAs
Wavelength Range	1250-1640 nm
Power Range	+10 to -80 dBm
Applicable Fiber Type	Standard SM and MM up to 62.5 μ m core size, NA ≤ 0.24
Uncertainty (accuracy) at Reference Conditions ^[1]	$\pm 3\%$ (1260 nm to 1630 nm)
Total Uncertainty ^[2]	$\pm 5\% \pm 20$ pW ^[8] (1260 nm to 1630 nm)
Relative Uncertainty Due to Polarization ^[3] Spectral Ripple (due to interference) ^[4]	± 0.015 dB typical ± 0.015 dB typical
Linearity (power) ^[5] - at 23°C $\pm 5^\circ$ C - at operating temp. range	CW +10 to -60 dBm (1260 to 1630 nm) $< \pm 0.02$ dB ± 20 pW ^[9] $< \pm 0.06$ dB ± 20 pW ^[9]
Return Loss ^[7]	> 40 dB
Noise (peak to peak) ^{[5],[6]}	< 20 pW
Averaging Time (minimal)	25 μ s
Dynamic Range at manual range mode ^{[5],[10]} - at +10 dBm Range - at ± 0 dBm Range - at -10 dBm Range - at -20 dBm Range	typ. > 55 dB typ. > 55 dB typ. > 52 dB typ. > 45 dB
Linearity (power) at manual range mode ^{[5],[11]} - at +10 dBm Range - at ± 0 dBm Range - at -10 dBm Range - at -20 dBm Range	CW +10 to -60 dBm (1260 to 1630 nm) typ. $< \pm 0.02$ dB ± 50 nW typ. $< \pm 0.02$ dB ± 5 nW typ. $< \pm 0.02$ dB ± 1 nW typ. $< \pm 0.02$ dB ± 500 pW
Alternating Signals	Only manual range mode
Analog Output	included
Dimensions (H x W x D)	75 mm \times 32 mm \times 335 mm (2.8" \times 1.3" \times 13.2")
Weight	0.5 kg
Recalibration Period	2 years
Operating Temperature	+10°C to +40°C
Humidity	Non-condensing
Warm-up time	20 minutes

Table 4 Fast Optical Power Sensor Module Specifications

Agilent 81636B	
<p>[1] Reference Conditions</p> <ul style="list-style-type: none"> • Power level 10 μW (\approx 20 dBm), continuous wave (CW) • Fiber 50 μm graded-index, NA=0.2 • Ambient temperature 23°C \pm 5°C • On day of calibration (add \pm 0.3% for ageing over one year; add \pm 0.6% over two years) • Spectral width of source < 10 nm (FWHM) • Wavelength setting at Power Meter must correspond to source wavelength \pm 0.4 nm 	
<p>[2] Operating Conditions:</p> <ul style="list-style-type: none"> • Fiber \leq 50 μm, NA \leq 0.2 • Within one year of calibration, add 0.3% for second year • Add \pm1% for Biconic connector • Operating temperature as specified, humidity: non-condensing 	
<p>[3] All states of polarization at constant wavelength (1550 nm \pm 30 nm) and constant power, straight connector, T=23°C\pm5 °C</p> <p>For angled connector (8°) add \pm 0.01 dB typ.</p>	
<p>[4] Conditions:</p> <p>Wavelength 1550 nm \pm 30 nm, fixed state of polarization, constant power, Temperature 23°C \pm 5°C</p> <p>Linewidth of source \geq 100 MHz, angled connector 8°.</p>	
<p>[5] At constant temperature (ΔT = \pm 1°C)</p>	
<p>[6] Averaging time 1 s, T = 23°C \pm 5 °C, observation time 300 s. Wavelength range 1260 - 1630 nm.</p>	
<p>[7] Conditions</p> <ul style="list-style-type: none"> • Wavelengths 1310 nm \pm 30 nm and 1550 nm \pm 30 nm • Standard single-mode fiber, angled connector min 8° • T= 23°C \pm 5 °C 	
<p>[8] For wavelengths >1600 nm add \pm0.06 %/nm</p>	
<p>[9] For input power >2 mW add \pm0.02 dB</p>	
<p>[10] Conditions:</p>	<p>Averaging time 25 μs, T = 23°C \pm 5</p> <p>Observation Time 2.5s</p>

Agilent 81630B Specification

	Agilent 81630B
Sensor Element	InGaAs
Wavelength Range	970 - 1650 nm
Power Range	+28 to -70dBm
Applicable Fiber Type	Standard SM and MM up to 100 μ m core size, NA \leq 0.3
Uncertainty (accuracy) at Reference Conditions ^[1]	$\pm 3.0\%$ for 1255 nm to 1630 nm at 980 nm $\pm 3.5\%$ (add $\pm 0.5\%$ per nm if 980 nm is not the center wavelength) at 1060 nm $\pm 4.0\%$ (add $\pm 0.6\%$ per nm if 1060 nm is not the center wavelength)
Total Uncertainty ^{[2], [8]}	$\pm 5.0\% \pm 1.2$ nW for 1255 nm to 1630 nm at 980 nm $\pm 5.5\% \pm 1.2$ nW (add $\pm 0.5\%$ per nm if 980 nm is not the center wavelength) at 1060 nm $\pm 6.0\% \pm 1.2$ nW (add $\pm 0.6\%$ per nm if 1060 nm is not the center wavelength)
Relative Uncertainty Due to Polarization ^[3]	$< \pm 0.01$ dB
Spectral Ripple (due to interference) ^[4]	$< \pm 0.005$ dB
Linearity (power) ^[5] - at 23°C $\pm 5^\circ$ C - at operating temp. range	CW +28 to -50 dBm 970 - 1630 nm $< \pm 0.05$ dB ± 1.2 nW ^[8] $< \pm 0.15$ dB ± 1.2 nW ^[8]
Return Loss ^[7]	> 55 dB
Noise (peak to peak) ^{[5], [6]}	< 1.2 nW
Averaging Time (minimal)	100 μ s
Analog Output	included
Dimensions (H x W x D)	75 mm \times 32 mm \times 335 mm (2.8" \times 1.3" \times 13.2")
Weight	0.6 kg
Recalibration Period	2 years
Operating Temperature	0°C to +35°C
Humidity	non-condensing
Warm-up time	20 minutes

	Agilent 81630B
[1] Reference Conditions	<ul style="list-style-type: none"> • Power level 80 μW, continuous wave (CW) • SM Fiber 9 μm graded-index, NA=0.1 • Ambient temperature 23°C \pm 5°C • On day of calibration (add \pm 0.3% for ageing over one year; add \pm 0.6% over two years) • Spectral width of source < 10 nm (FWHM) • Wavelength setting at Power Meter must correspond to source wavelength \pm 0.4 nm
[2] Operating Conditions:	<ul style="list-style-type: none"> • Fiber \leq 50 μm, NA \leq 0.2 • Within one year of calibration, add 0.3% for second year • Add \pm 1% for Biconic connector • Operating temperature as specified, humidity: non-condensing
[3] All states of polarization at constant wavelength (1550 nm \pm 30 nm) and constant power, straight connector, T=23°C\pm5 °C	For angled connector (8°) add \pm 0.01 dB typ.
[4] Conditions:	Wavelength 1550 nm \pm 30 nm, fixed state of polarization, constant power, Temperature 23°C \pm 5°C Linewidth of source \geq 100 MHz, angled connector 8°
[5] At constant temperature (ΔT = \pm 1°C)	
[6] Averaging time 1 s, T = 23°C \pm 5 °C, observation time 300 s. Wavelength range 1255 - 1630 nm.	
[7] Conditions	<ul style="list-style-type: none"> • Wavelengths 1310 nm \pm 30 nm and 1550 nm \pm 30 nm • Standard single-mode fiber, angled connector min 8° • T= 23°C \pm 5 °C
[8] For input power > +10 mW add:	typ. \pm 0.0012 dB/mW In case of negative power change > 50 dB allow additional recovery time of 3 min.
[9] 30°C for > + 20dBm input power	

Supplementary Performance Characteristics

Analog Output

Bandwidth \geq DC, \leq 300 to 5000 Hz depending on range and optical head.

Output voltage 0 to 2 V into open

Output impedance 600 ohm typ.

Max. input voltage \pm 10V

Table 5 3dB-bandwidth of the Analog Output

Range	Bandwidth 81630B	Bandwidth 81635A	Bandwidth 81634B	Bandwidth 81636B
+30 dBm	3.5 kHz			
+20 dBm	3.5 kHz			
+10 dBm	3.5 kHz		5.0 kHz	17 kHz
0 dBm	3.5 kHz		5.0 kHz	17 kHz
-10 dBm	3.0 kHz		5.0 kHz	17 kHz
-20 dBm	3.0 kHz		5.0 kHz	17 kHz
-30 dBm	0.3 kHz		4.0 kHz	
-40 dBm	0.3 kHz		4.0 kHz	
-50 dBm	0.3 kHz		0.3 kHz	
-60 dBm	-		0.3 kHz	
-70 dBm	-			

4

Performance Tests

The procedures in this section test the performance of the instrument. The complete specifications to which the Agilent 81630B/4B/6B Power Sensor Modules and the Agilent 81635A Dual Power Sensor Module are tested are given in “Specifications” on page 19. All tests can be performed without access to the interior of the instrument. The performance tests refer specifically to tests using the Diamond HMS-10/Agilent connector.

Equipment Required	34
Test Record	35
Test Failure	35
Instrument Specification	35
Performance Test Procedures	36
Accuracy Test	37
Linearity Test	39
Example: Measurement Results	45
Noise Test	48
Return Loss Test	49
Relative Uncertainty due to Polarization (Optional Test)	51
Relative Uncertainty due to Interference (Optional Test)	53
Test Record Sheets	56

Equipment Required

Equipment required for the performance test is listed in the table below. Any equipment that satisfies the critical specifications of the equipment given in the table may be substituted for the recommended models.

Table 5 Required Equipment

Instrument/Accessory	Recommended Model	81636B	81635A	81634B	81630B	Required Characteristics	Alternative Models
Multimeter Mainframe	Agilent 8163A/B (2 each)	x	x	x	x		Agilent 8164A/B
CW Laser Module	Agilent 81657A	x	x	x	x		
Power Meter Standard	Agilent 81618A Optical Head Interface Module with Agilent 81624B #C01 Working Standard Optical Head	x	x	x	x		
Power Sensor Module	Agilent 81634B	x	x	x	x		
Optical Attenuator	Agilent 8156A #221	x	x	x	x		
Optical Attenuator	Agilent 8156A #101	x	x	x	x		81560A
Return Loss Module	Agilent 81613A	x	x	x	x		
Return Loss Reference Cable	Agilent 81610CC	x	x	x	x		
Tunable Laser Source	Agilent 8164A/B and Agilent 81680A #022	-		o	o		8168E/F #022
Polarization Controller	11896A	-	-	o	o		
Wavelength Independent Coupler (3 dB)	Special Tool	-	-	o	o		
Best IF Adapter	Special Tool	-	-	o	o		
Singlemode Fiber	Agilent 81101AC (2 each)	x	x	x	x		
	Agilent 81113PC (3 each)	x	x	x	x		
	Agilent 81113SC (1 each)	x	x	x	x		
Connector Adapters	Agilent 81000AA (1 each)	x	x	x	x		
Connector Interfaces	Agilent 81000AI (4 each)	x	x	x	x		
	Agilent 81000FI (3 each)	x	x	x	x		
	Agilent 81000SI (4 each)	x	x	x	x		
Plastic Cap	PN 5040-9351	x	x	x	x		
Legend: - not applicable x necessary o optional							

Test Record

Results of the performance test may be tabulated on the Test Record provided at the end of the test procedures. It is recommended that you fill out the Test Record and refer to it while doing the test. Since the test limits and setup information are printed on the Test Record for easy reference, the record can also be used as an abbreviated test procedure (if you are already familiar with the test procedures). The Test Record can also be used as a permanent record and may be reproduced without written permission from Agilent Technologies.

Test Failure

If the Agilent 81630B/4B/5B/6B fails any performance test, return the instrument to the nearest Agilent Technologies Sales/Service Office for repair.

Instrument Specification

Specifications are the performance characteristics of the instrument that is certified. These specifications, listed in *"Specifications" on page 19*, are the performance standards or limits against which the Agilent 81630B/4B/5B/6B can be tested. *"Specifications" on page 19* also lists some supplemental characteristics of the Agilent 81630B/4B/5A/6B. Supplemental characteristics should be considered as additional information.

Any changes in the specifications due to manufacturing changes, design, or traceability to the National Institute of Standards and Technology (NIST), will be covered in a manual change supplement, or revised manual. Such specifications supercede any that were previously published.

Performance Test Procedures

The performance test given in this section includes the Accuracy Test, the Linearity Test, the Return Loss Test and the Noise Test. The performance test for the Agilent 81630B, 81634B also includes – as optional tests – the Relative Polarization Uncertainty and the Relative Interference Uncertainty Test. Perform each step in the order given, using the corresponding test equipment.

NOTE

Make sure that all optical connections are dry and clean. **DO NOT USE INDEX MATCHING OIL.** For cleaning, use the cleaning instructions given in *“Cleaning Instructions” on page 75.*

Fix the optical cables that connect the laser source and Power Meter to the Agilent 8156A Attenuator. This ensures minimum cable movement during the tests.

Accuracy Test

NOTE

The linearity test must only be performed at either 1310 nm or 1550 nm. The accuracy test must be performed in the -20 dBm range at 10 μ W at both 1310 nm and 1550 nm.

Test Setup

- 1 Make sure that cable connector, detectors and adapters are clean.
- 2 Connect the equipment as shown in Figure 3. Ensure that the cables to and from the attenuator are fixed on the table and that both the optical head and the DUT are close together so that minimum cable movement is required when connecting the cable to the head or to the DUT.
- 3 Move to the Laser Source channel, move to the wavelength parameter, [λ], press *Enter*, select the lower wavelength source, and press *Enter*.
- 4 If you are using an Agilent 81657A Laser Source ensure that you initialize the Agilent 8156A Optical Attenuator with 30 dB attenuation.

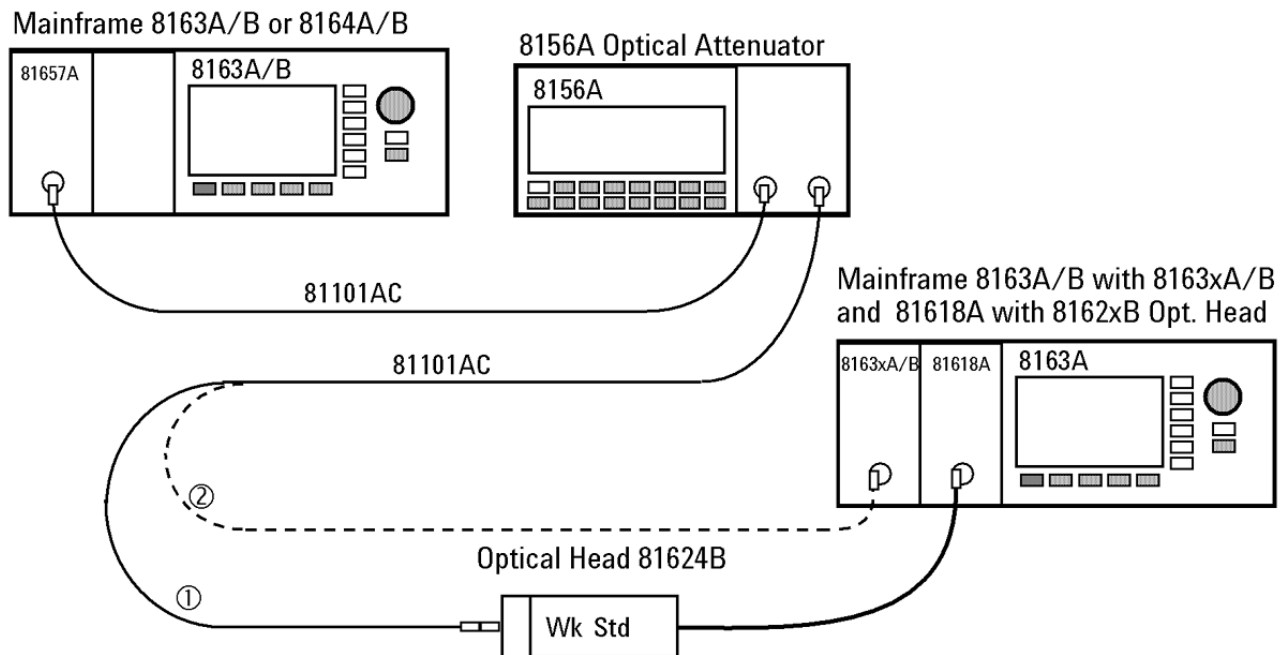

Figure 3 Accuracy Test Setup

- 5 Turn the instruments on, enable the laser source and allow the instruments to warm up for at least 20 minutes.
- 6 Perform the following sub-procedure for both Power Meters:

- a Move to the Power Meter channel.
 - b Move to the wavelength parameter, [λ], press *Enter*, enter the wavelength of the laser source, and press *Enter*.
 - c Move to the calibration parameter, [*CAL*], press *Enter*, set the calibration parameter to zero, and press *Enter*.
 - d Move to the averaging time parameter, [*AvgTime*], press *Enter*, move to *<500 ms>*, and press *Enter*.
 - e Move to the power parameter, [*P*], press [Pwr unit], move to *<Watt>*, and press *Enter*.
- 7 Make sure the optical input of the Device Under Test (DUT), 8163xA, is not receiving any light by placing a plastic cap over the input. Move to the DUT Power Meter channel, press [Menu], move to *<Zero>*, press *Enter*.
- 8 Ensure that the Agilent 8156A output is disabled. Move to the reference Power Meter channel, 81624B/81618A, press [Menu], move to *<Zero>*, press *Enter*.
- 9 Enable the Agilent 8156A output and change the attenuation until the reference Power Meter displays 10.00 μ W.
- 10 Connect the attenuator output cable to the DUT Power Meter. Note the power value returned from the DUT, [*P*], from the display and note the result in the test record.
- 11 Move to the Laser Source channel, move to the wavelength parameter, [λ], press *Enter*, select the longer wavelength source, and press *Enter*.
- 12 Repeat steps 4 to 10 at the second wavelength with the corresponding source.

Linearity Test

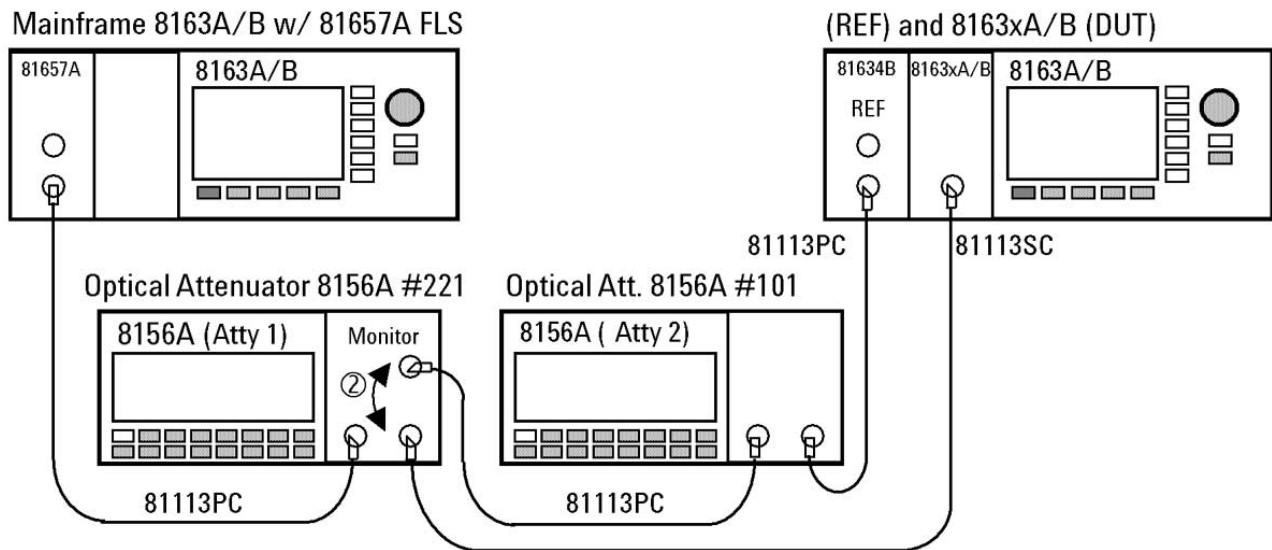

Figure 4 Measurement Setup for Power Linearity

NOTE

- Do not turn the laser off during the measurement!
- Clean all connectors carefully before you start with the measurement!

Test Setup

- 1 Make sure that cable connector, detectors and adapters are clean.
- 2 Make sure that you perform this test in a temperature-controlled environment with temperature fluctuations less than $\pm 1^{\circ}\text{C}$.
- 3 Setup the equipment as shown in Figure 4 . Disable both attenuators and enable the laser source, where the source wavelength is chosen to 1550 nm. If you are using the 81657A, move to the wavelength parameter, [λ], press *Enter*, select the longer wavelength source (1550 nm nominally), and press *Enter*.
- 4 Set the wavelength of both attenuators to the same wavelength as the laser source.
- 5 Perform the following sub-procedure for both Power Meters:
 - a Move to the Power Meter channel.
 - b Move to the wavelength parameter, [λ], press *Enter*, enter the wavelength of the laser source, and press *Enter*.

- c Move to the calibration parameter, [CAL], press *Enter*, set the calibration parameter to zero, and press *Enter*.
 - d Move to the averaging time parameter, [AvgTime], press *Enter*, move to <100 ms>, and press *Enter*.
 - e Move to the power parameter, [P], press [Pwr unit], move to <dBm>, and press *Enter*.
 - f Press the [Menu] softkey and move to <Number of digits>, press *Enter*, move to <3>, press *Enter* and press [Close].
- 6** Initialize the two attenuators as follows:
- a Set the attenuation of the 8156A #221 with Monitor Output (referred to as Atty1) to 0 dB.
 - b Set the attenuation of the other 8156A (referred to as Atty2) to 45 dB.
- 7** Wait at least 15 minutes until the laser source is stabilized.
- 8** Perform the following sub-procedure for the reference Power Meter, 81634B:
- a Press [Menu], move to <Range mode>, move to <Manual>, and press *Enter*.
 - b Move to <Range>, press *Enter*, move to <-50 dBm>, press *Enter*, and press [Close].
- 9** Perform the following sub-procedure for the DUT, 8163xA/B:
- a Press [Menu], move to <Range mode>, move to <Manual>, and press *Enter*.
 - b Move to <Range>, press *Enter*, move to <10 dBm>, and press *Enter*.
 - c Zero both Power Meters. Move to <Zero all> and press *Enter*.
- 10** Enable both attenuators.
- 11** Adjust the attenuation of Atty2 in order to achieve -47.2 dBm on the reference Power Meter.

+10 dBm Range

- 12 Applies to the 81630B only: Switch to the 20 dBm range and note both power readings as n=0 in the test record, which is given at the end of the test description (#0, i.e. n=0). Always note at least three digits after the delimiter in the test record. Switch back to the 10 dBm range.
- 13 Note both power readings as the first value in the test record, which is given at the end of the test descriptions (#1). Always note at least three digits after the delimiter in the test record.
- 14 Increase the attenuation of Atty1 until the power reading of the DUT shows about +2.8 dBm.
- 15 Note the InRange-values in the test record (#2)
- 16 Perform the following sub-procedure for the DUT, 8163xA/B:
 - a Press [Menu], move to *<Range mode>*, move to *<Manual>*, and press *Enter*.
 - b Move to *<Range>*, press *Enter*, move to *<0 dBm>*, and press *Enter*.
- 17 If necessary, adjust the attenuation of Atty2 in order to be on the upper limit of the -50 dBm range (i.e. -47.2 dBm).

0 dBm Range

- 18 Disable Atty1.
- 19 Zero both Power Meters. On the 8163A/B with two installed power meters, press [Menu], move to *<Zero all>*, and press *Enter*.
- 20 Enable Atty1.
- 21 Switch one range up to the +10dBm range.
- 22 Note both power readings (#3).
- 23 Switch down to the previous range (0dBm) and note the values again (#4).
- 24 Increase Atty1 by 10 dB and note the results in the test record (#5).
- 25 At the DUT, 8163xA/B, press [Menu], move to *<Range>*, press *Enter*, move to *<-10 dBm>*, and press *Enter* and press *Close*.
- 26 If necessary, adjust the attenuation of Atty1 in order to be on the upper limit of the range (i.e. -x7.y dBm).
- 27 Decrease the attenuation of Atty2 by 10 dB in order to be on the upper limit of the -50 dBm range.

-10 dBm Range

28 Disable Atty1.

29 Zero both Power Meters. On the 8163A/B with two installed power meters, press [Menu], move to <Zero all>, and press *Enter*.

30 Enable Atty1.

31 Switch one range up to the 0 dBm range and note the power readings (#6).

32 Switch down to the previous range (-10 dBm) and note the values again (#7).

33 Increase the attenuation of Atty1 by 10 dB and note the results in the test record (#8).

34 On the DUT switch one range down to the -20 dBm range.

35 Decrease the attenuation of Atty2 by 10 dB in order to be on the upper limit of the -50 dBm range.

-20 dBm Range

36 Disable Atty1.

37 Zero both Power Meters. On the 8163A/B with two installed power meters, press [Menu], move to <Zero all>, and press *Enter*.

38 Enable Atty1.

39 Switch one range up to the -10 dBm range and note the power readings (#9).

40 Switch down to the previous range (-20 dBm) and note the values again (#10)

41 Increase the attenuation of Atty1 by 10 dB and note the results in the test record (#11).

42 On the DUT switch one range down to the -30dBm range

43 Decrease the attenuation of Atty2 by 10 dB in order to be on the upper limit of the -50 dBm range.

-30 dBm Range

- 44** Disable Atty1.
- 45** Zero both Power Meters. On the 8163A/B with two installed power meters, press [Menu], move to <Zero all>, and press Enter.
- 46** Enable Atty1.
- 47** Switch one range up to the -20 dBm range and note the power readings (#12)
- 48** Switch down to the previous range (-30 dBm) and note the values again (#13).
- 49** Increase the attenuation of Atty1 by 10 dB and note the results in the test record (#14).
- 50** On the DUT Switch one range down to the -40 dBm range.

Change Setup

- 51** Disable Atty1 and switch the output with the monitor output.
- 52** Set the attenuation of Atty1 to 35 dB and of Atty2 to 25 dB.
- 53** Enable Atty1 again.
- 54** Adjust the attenuation of both attenuators in the following order:
 - Atty1: DUT Power Meter shows a reading of -37.2 dBm and
 - Atty2: the REF Power Meter shows a reading of -47.2 dBm.

-40 dBm Range

- 55** Disable Atty1.
- 56** Zero both Power Meters. On the 8163A/B with two installed power meters, press [Menu], move to <Zero all>, and press *Enter*.
- 57** Enable Atty1.
- 58** Switch one range up to the -30 dBm range and note both power readings (#15).
- 59** Switch one range down (-40 dBm) and note the power readings again (#16).
- 60** Increase the attenuation of Atty1 by 10 dB and note the results in the test record (#17).
- 61** On the DUT switch one range down to the -50 dBm range.
- 62** Decrease the attenuation of Atty2 by 10 dB in order to be on the upper limit of the -50 dBm range.

-50 dBm Range

63 Disable Atty1.

64 Zero both Power Meters. On the 8163A/B with two installed power meters, press [Menu], move to <Zero all>, and press Enter.

65 Enable Atty1

66 Switch one range up to the -40 dBm range and note the power readings (#18).

67 Switch one range down (-50 dBm) and note the power readings (#19)

68 Increase the attenuation of Atty1 by 10 dB and note the results in the test record (#20).

Calculation

69 Calculate the non-linearity using the formulas given in the test records.

Example: Measurement Results

Information only				Your Entries		Notes
n	Atty1 / #221 [dB]	Atty2 / #100 [dB]	DUT Range [dBm]	REF Power [dBm]	DUT Power [dBm]	
1	0	40,5	10	-47,210	10,215	1. Value
2	7,4	40,5	10	-54,592	2,828	InRange
3	7,4	33,1	10	-47,196	2,829	RangeDisc / lower limit
4	7,4	33,1	0	-47,196	2,829	RangeDisc / upper limit
5	17,4	33,1	0	-57,186	-7,162	InRange
6	17,4	23,1	0	-47,196	-7,164	RangeDisc / lower limit
7	17,4	23,1	-10	-47,197	-7,165	RangeDisc / upper limit
8	27,4	23,1	-10	-57,186	-17,155	InRange
9	27,4	13,1	-10	-47,196	-17,155	RangeDisc / lower limit
10	27,4	13,1	-20	-47,197	-17,156	RangeDisc / upper limit
11	37,4	13,1	-20	-57,201	-27,162	InRange
12	37,4	3,1	-20	-47,208	-27,161	RangeDisc / lower limit
13	37,4	3,1	-30	-47,209	-27,162	RangeDisc / upper limit
14	47,4	3,1	-30	-57,213	-37,166	InRange
15	35,6	16,5	-30	-47,292	-37,281	RangeDisc / lower limit
16	35,6	16,5	-40	-47,293	-37,282	RangeDisc / upper limit
17	45,6	16,5	-40	-57,295	-47,285	InRange
18	45,6	6,5	-40	-47,298	-47,281	RangeDisc / lower limit
19	45,6	6,5	-50	-47,298	-47,282	RangeDisc / upper limit
20	55,6	6,5	-50	-57,300	-57,284	InRange

Calculations

n	Conversion [dBm] → [mW]		Calculation as given			Calculation as given			
	Ref / R [mW]	DUT / D [mW]	Relation 1 A(n)	$= R_{n+1}/R_n$	Relation 2 B(n)	Non-Linearity $= A_n * B_n (NL_{n\pm 1} + 1) - 1$ ① [%]			
1	1,90108E-05	10,50751455	0,182725854		$= R_{n+1}/R_n$		0,182515604	$= D_n/D_{n+1}$	0,16
2	3,47376E-06	1,917785364							
3	1,90722E-05	1,918227002	1	1					0,05
4	1,90722E-05	1,918227002	0,100230524	0,100207448					0,05
5	1,91161E-06	0,192220632							
6	1,90722E-05	0,192132131	0,999769768	0,999769768					0,02
7	1,90678E-05	0,192087896	0,100253605	0,100230524					0,02
8	1,91161E-06	0,01925307							
9	1,90722E-05	0,01925307	0,999769768	0,999769768					0,00
10	1,90678E-05	0,019248638	Reference Level				0,00		
11	1,90502E-06	0,001922206	10,00921458	$= R_{n-1}/R_n$	10,01382506	$= D_n/D_{n-1}$	-0,05		
12	1,90195E-05	0,001922649							
13	1,90152E-05	0,001922206	1,000230285		1,000230285				-0,05
14	1,89977E-06	0,000192044	10,00921458		10,00921458				-0,05
15	1,86552E-05	0,000187025							
16	1,86509E-05	0,000186982	1,000230285		1,000230285				-0,05
17	1,86423E-06	1,86853E-05	10,00460623		10,00691014				-0,07
18	1,86294E-05	1,87025E-05							
19	1,86294E-05	1,86982E-05	1		1,000230285				-0,09
20	1,86209E-06	1,86896E-06	10,00460623		10,00460623				-0,09

NOTE

① : The Nonlinearity is calculated recursively using n=10 as reference point. The formula is:

$$NL_n = \begin{cases} A_n \times B_n \times \langle NL_{n+1} + 1 \rangle - 1 & \text{for } n < 10 \\ A_n \times B_n \times \langle NL_{n-1} + 1 \rangle - 1 & \text{for } n > 10 \end{cases}$$

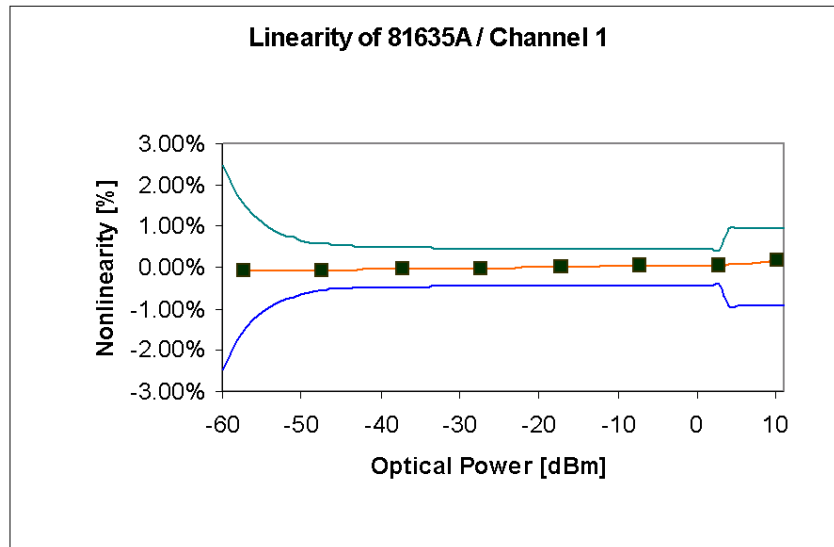

Figure 5 Linearity Test

Noise Test

- 1** Insert the device under test, a 8163xA/B Power Sensor, into a slot of the 8163A/B mainframe. Make sure the optical input of the Device Under Test (DUT), 8163xA, is not receiving any light by placing a plastic cap over the input. Move to the DUT Power Meter channel, press [Menu], move to <Zero>, and press *Enter*.
- 2** Press *Appl*, move to <Stability>, and press *Enter*. The Stability Setup Screen appears.
- 3** Ensure, that the correct channel is selected in the upcoming Module Selection box.
- 4** Press [Menu] to access the Logging application menu screen.
- 5** Move to <Pwr unit>, press *Enter*, move to <W>, and press *Enter*.
- 6** Move to <AvgTime>, press *Enter*, move to <1 s>, and press *Enter*.
- 7** Move to <Range mode>, press *Enter*, move to <Auto>, and press *Enter*, and press [Close].
- 8** Press the [Parameter] softkey, move to [TotalTime], press *Enter*, set the total time to 00:05:00, which is 5 minutes, and press *Enter*.
- 9** Press the [Measure] softkey to start the measurement.
- 10** After the stability application has finished, press the [Analysis] softkey, press the [more] softkey, and note [ΔP] as the noise value in the test record.

Return Loss Test

- 1 Make sure that all connectors are clean.
- 2 Set up the equipment as shown in Figure 6 .
- 3 Press [*Preset*] on the mainframe.

Mainframe 8163B or 8164B w/
81657A and 8163xA/B (DUT)

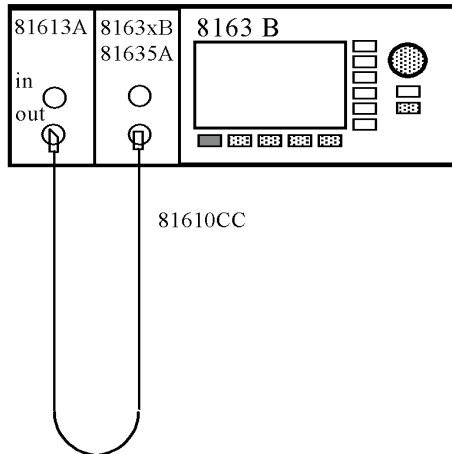

Figure 6 Return Loss Measurement Setup

NOTE

To ensure traceability, use the 81610CC Reference Cable for calibration measurements. Do **not** use the 81610CC Reference Cable for measurements on a Device Under Test. Instead, use a measurement patchcord.

CAUTION

It is important to maintain the quality of the straight connector end of the 81610CC Reference Cable. **Never** add another connector to the straight end of the 81610CC Reference Cable, since a physical connection is made. When the straight end of the 81610CC Reference Cable is connected to the 81634B Power Sensor module, no physical connection is made so there should be no degradation of connector quality.

- 4 Zero the Return Loss Module and the Power Sensor Module
- 5 Enable the internal laser source of the Return Loss Module and allow 20 minutes for it to stabilize.
- 6 At the Power Meter:
 - a Set the averaging time [*AvTime*] to 1s

- b Set the wavelength [λ] to the wavelength of the RTL source.
 - c Set [Pwr unit] to <db>.
- 7** At the Return Loss Module:
- a Set the averaging time [AvTime] to 1s.
 - b Enter the Return Loss Reference value RLref of the 81610CC reference cable for this wavelength.
 - c Press [RefCal] to calibrate the Return Loss module at reference condition.
- 8** At the Power Meter press [Disp -> Ref]. The Power Meter should now read 0.0 dB.
- 9** Disconnect the 81610CC Reference Cable from the setup and connect a 81113SC user cable to the Return Loss Module and leave the other end open as shown in Figure 8.

Mainframe 8163B or 8164B w/
81657A and 8163xA/B (DUT)

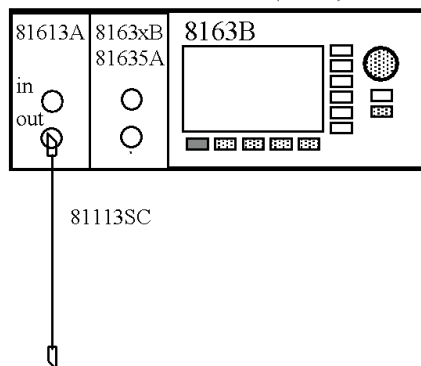

Figure 7 Return Loss Measurement Setup

- 10** At the Return Loss Module, press [TermCal] in order to calibrate the Return Loss Module at termination condition.
- 11** Connect the open end to the Power Sensor Module.
- 12** Enter the Power reading [P] on the Power Sensor Module as [FPDelta] on the Return Loss Meter. Make sure you enter the sign of this value correctly.
- 13** Note the Return Loss reading as the Return Loss result into the test record.

Relative Uncertainty due to Polarization (Optional Test)

NOTE

The performance test "Relative Uncertainty due to Polarization" is optional, since the polarization is given with the production of the unit by mechanical and optical cavities and stays unchanged by normal use of the sensor module.

Below, you will find the test setup to verify the relative uncertainty due to polarization of the sensor module. Generally, during this measurement-procedure the tunable laser source is swept through a predefined wavelength range. After every wavelength step, a single PDL-measurement is made, where the polarization controller generates all different polarization states. The highest PDL value is taken as the "relative uncertainty due to polarization". The low output power path of the coupler is used to monitor the power stability of the setup

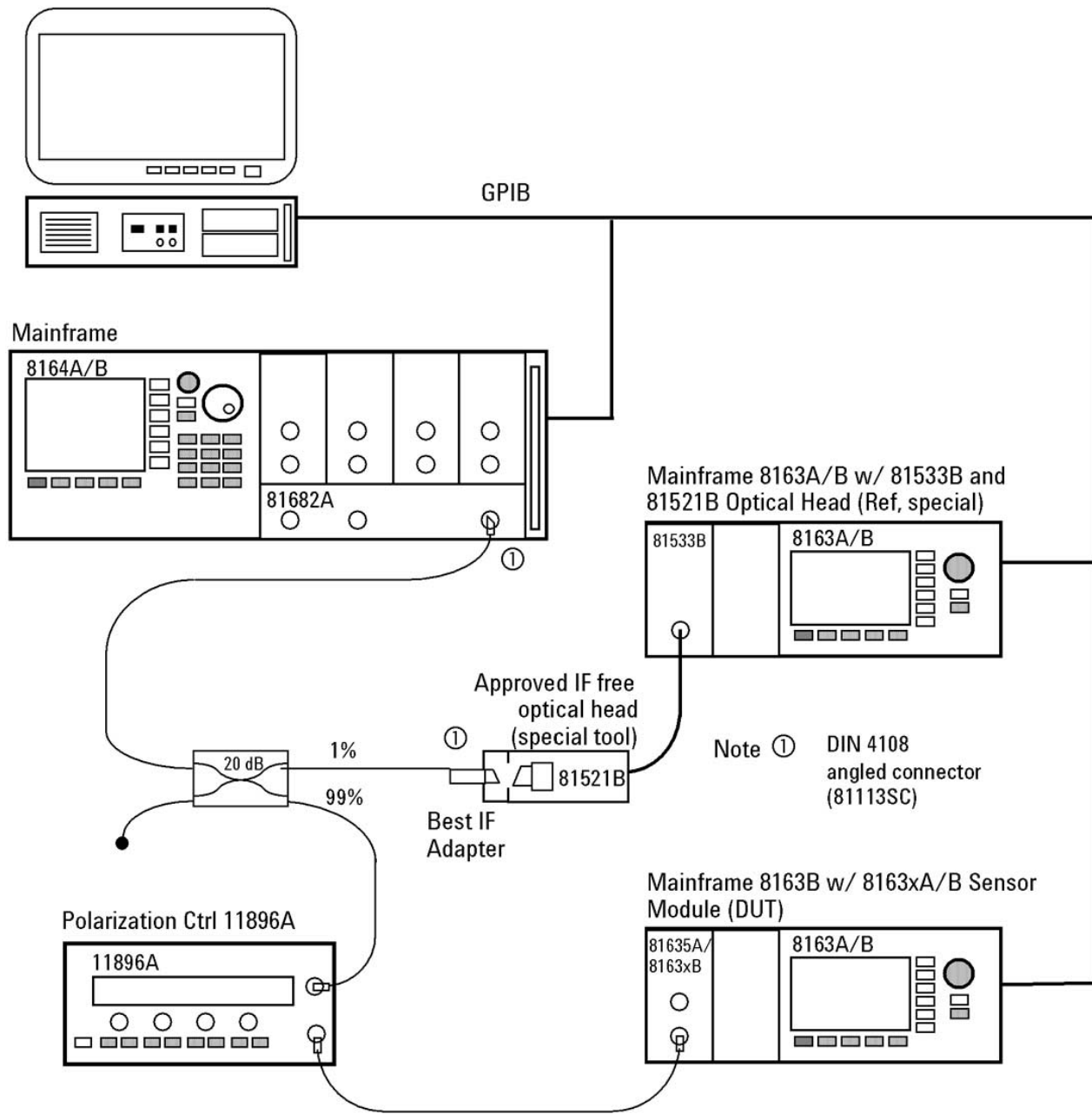

Figure 8 Measurement Setup for PDL Test

Relative Uncertainty due to Interference (Optional Test)

NOTE

The performance test "Relative Uncertainty due to Interference" is optional, since the interference is given with the production of the unit by mechanical and optical cavities and stays unchanged by normal use of the sensor module.

Below, you will find the test setup to verify the relative uncertainty due to interference of the sensor module. In order to perform the relative uncertainty due to interference test, it is mandatory to use two mainframes, since the time difference between measurement A and B for a specific wavelength point has to be at most 2 ms. Due to this short measurement interval, the performance test of the relative uncertainty due to interference can only be using computer control.

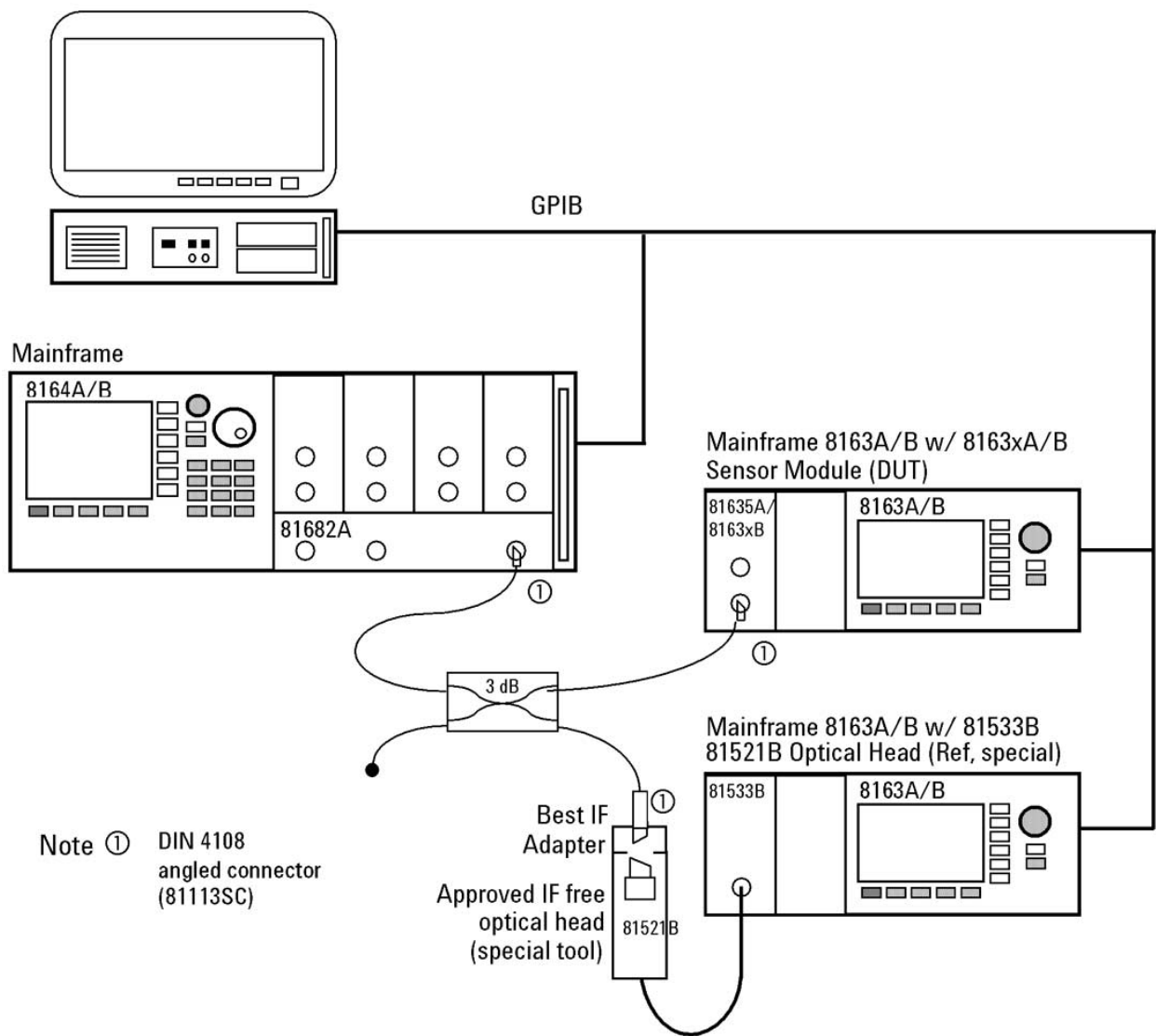

Figure 9 Setup for Relative Uncertainty due to Interference Measurement

Theoretically, both Power Meters are monitoring the power ratio over the variable wavelength in a predefined range as shown in Figure 10 . Ensure that the tunable laser source is mode-hop free in the tested wavelength range.

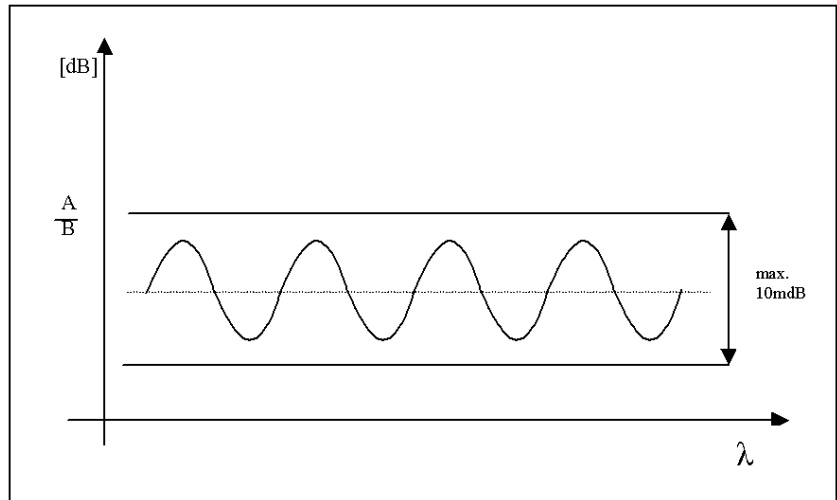

Figure 10 Interference Ripple

Test Record Sheets

Performance Test for the Agilent 81630B

Page 1 of 3

Model	Agilent 81630B Sensor Module_____	Date	_____
Serial No.	_____	Ambient Temperature	_____ °C
Options	_____	Relative Humidity	_____ %
Firmware Rev.	_____	Line Frequency	_____ Hz
Test Facility	_____	Customer	_____
Performed by	_____	Report No	_____

Special Notes

Performance Test for the Agilent 81630B

Test Equipment Used

Page 2 of 3

	Description	Model No.	Trace No	Cal. Due Date
1a1	Lightwave Multimeter (Std.)	Agilent 8163A/B	_____	_____
1a2	Lightwave Multimeter (DUT)	Agilent 8163A/B	_____	_____
1b	TLS Mainframe	Agilent 816A/4B	_____	_____
2	CW Laser Source	Agilent 81657A	_____	_____
3a	Opt. Head Interface Module	81618A	_____	_____
3b	Optical Head, Reference	81624B	_____	_____
4	Sensor Module	81630B	_____	_____
5a	Optical Attenuator	8156A #221	_____	_____
5b	Optical Attenuator	8156A #101	_____	_____
6	Return Loss Module	81613A	_____	_____
79	_____	_____	_____	_____
8	_____	_____	_____	_____
9	_____	_____	_____	_____
10	_____	_____	_____	_____

Accessories	#	Product	#	Product	#	Product
Singlemode Fibers	2	81101AC	1	81113SC	3	81113PC
Connector Interfaces	4	81000AI	3	81000FI	4	81000SI
Connector Adapters	1	81000AA				

Performance Test for the Agilent 81630B

Page 3 of 3

Model Agilent 81630B Sensor Module		Report No. _____	Date _____		
Test No.	Test Description	Min. Spec.	Result	Max. Spec.	Measurement Uncertainty
I	Accuracy Test		[μW]		
	measured at _____ nm (1310nm) Output Power	9.64 μW	_____	10.36 μW	
	measured at _____ nm (1550nm) Output Power	9.64 μW	_____	10.36 μW	
II	Linearity Test	For Calculations you may want to use the appropriate sheet			
	Range	P_{DUT} [dBm]	P_{DUT} [dBm]	Loss [%]	
	+20	+10	_____	_____	< \pm 1.24 ¹ %
	+10	+10	_____	_____	< \pm 1.16 %
	+10	+3	_____	_____	< \pm 1.16 %
	0	+3	_____	_____	< \pm 1.16 %
	0	-7	_____	_____	< \pm 1.16 %
	-10	-7	_____	_____	< \pm 1.16 %
	-10	-17	_____	_____	< \pm 1.17 %
	-20*	-17*	Reference	0.0	< \pm 1.17 %
	-20	-27	_____	_____	< \pm 1.22 %
	-30	-27	_____	_____	< \pm 1.22 %
	-30	-37	_____	_____	< \pm 1.76%
	-40	-37	_____	_____	< \pm 1.76 %
	-40	-47	_____	_____	< \pm 7.17 %
III	Noise Test		[pW]		
			_____		< 1.2 nW
IV	Return Loss Test		[dB]		
		55 dB <	_____		
(V)	Relative Uncertainty due to Polarization		[dB]		
	Maximum difference in interval 1520 nm - 1580 nm / 0.75 nm step; ΔP		_____		< 0.01 dB
(VI)	Relative Uncertainty due to Interference		[dB]		
	Maximum difference/FSR in interval 1520 nm - 1580 nm / 10 pm step; ΔP		_____		< 0.005 dB

[1] The 20 dBm range measurement is only performed to check the functionality of the current booster. The published specification does not apply to operation in non-automode as used here to check this functionality.

NOTE

The non-linearity of the 81630B is not regularly tested up to the specified power level of +28 dBm. Instead, limited testing up to +10 dBm is used to test the electronic circuitry and diode of the 81630B. Above +10 dBm, the largest contribution to non-linearity comes from the absorbing glass filter that does not change its non-linearity with time. This way it is guaranteed by design that testing the 81630B up to +10 dBm ensures specification compliance up to +28 dBm.

Performance Test for the Agilent 81634B

Page 1 of 3

Model	Agilent 81634B Sensor Module____	Date	_____
Serial No.	_____	Ambient Temperature	_____ °C
Options	_____	Relative Humidity	_____ %
Firmware Rev.	_____	Line Frequency	_____ Hz

Test Facility	_____	Customer	_____
Performed by	_____	Report No	_____

Special Notes

Performance Test for the Agilent 81634B

Test Equipment Used

Page 2 of 3

	Description	Model No.	Trace No
1a1	Lightwave Multimeter (Std.)	Agilent 8163A/B	_____
1a2	Lightwave Multimeter (DUT)	Agilent 8163A/B	_____
1b	TLS Mainframe	Agilent 8164A/B	_____
2	CW Laser Source	Agilent 81657A	_____
3a	Opt. Head Interface Module	Agilent 81618A	_____
3b	Optical Head, Reference	Agilent 81624B	_____
4	Sensor Module	Agilent 81634B	_____
5a	Optical Attenuator	Agilent 8156A #221	_____
5b	Optical Attenuator	Agilent 8156A #101	_____
6	Return Loss Module	Agilent 81613A	_____
7	_____	_____	_____
8	_____	_____	_____
9	_____	_____	_____
10	_____	_____	_____

Accessories	#	Product	#	Product	#	Product
Singlemode Fibers	2	81101AC	1	81113SC	3	81113PC
Connector Interfaces	4	81000AI	3	81000FI	4	81000SI
Connector Adapters	1	81000AA				

Performance Test for the Agilent 81634B

Page 3 of 3

Model Agilent 81634B Sensor Module		Report No. _____	Date _____		
Test No.	Test Description	Min. Spec.	Result	Max. Spec.	Measurement Uncertainty
I	Accuracy Test		[μW]		
	measured at _____ nm (1310nm) Output Power	9.69 μW	_____	10.31 μW	
	measured at _____ nm (1550nm) Output Power	9.69 μW	_____	10.31 μW	
II	Linearity Test	For Calculations you may want to use the appropriate sheet			
	Range	P_{DUT} [dBm]	P_{DUT} [dBm]	Loss [%]	
	+10	+9	_____	_____	< \pm 0.35 %
	+10	+3	_____	_____	< \pm 0.35 %
	0	+3	_____	_____	< \pm 0.35 %
	0	-7	_____	_____	< \pm 0.35 %
	-10	-7	_____	_____	< \pm 0.35 %
	-10	-17	_____	_____	< \pm 0.35 %
	-20*	-17*	Reference	0.0	< \pm 0.35 %
	-20	-27	_____	_____	< \pm 0.35 %
	-30	-27	_____	_____	< \pm 0.35 %
	-30	-37	_____	_____	< \pm 0.35 %
	-40	-37	_____	_____	< \pm 0.35 %
	-40	-47	_____	_____	< \pm 0.35 %
	-50	-47	_____	_____	< \pm 0.35 %
	-50	-57	_____	_____	< \pm 0.36 %
III	Noise Test		[pW]		
			_____		< 0.2 pW
IV	Return Loss Test		[dB]		
		55 dB <	_____		
(V)	Relative Uncertainty due to Polarization		[dB]		
	Maximum difference in interval 1550 nm - 1560 nm / 0.1 nm step; ΔP		_____		< \pm 0.01 dB
(VI)	Relative Uncertainty due to Interference		[dB]		
	Maximum difference in interval 1500 nm - 1560 nm / 2 pm step; ΔP		_____		< \pm 0.05 dB

Performance Test for the Agilent 81635A

Page 1 of 3

Model	Agilent 81635A Sensor Module_____	Date	_____
Serial No.	_____	Ambient Temperature	_____ °C
Options	_____	Relative Humidity	_____ %
Firmware Rev.	_____	Line Frequency	_____ Hz

Test Facility	_____	Customer	_____
Performed by	_____	Report No	_____

Special Notes

Performance Test for the Agilent 81635A**Test Equipment Used**

Page 2 of 3

	Description	Model No.	Trace No
1a1	Lightwave Multimeter (Std.)	Agilent 8163A/B	_____
1a2	Lightwave Multimeter (DUT)	Agilent 8163A/B	_____
1b	TLS Mainframe	Agilent 8164A/B	_____
2b	CW Laser Source	Agilent 81657A	_____
3a	Opt. Head Interface Module	Agilent 81618A	_____
3b	Optical Head, Reference	Agilent 81624B	_____
4	Sensor Module	Agilent 81634B	_____
5a	Optical Attenuator	Agilent 8156A #221	_____
5b	Optical Attenuator	Agilent 8156A #101	_____
6	Return Loss Module	Agilent 81613A	_____
7	_____	_____	_____
8	_____	_____	_____
9	_____	_____	_____
10	_____	_____	_____

Accessories	#	Product	#	Product	#	Product
Singlemode Fibers	2	81101AC	1	81113SC	3	81113PC
Connector Interfaces	4	81000AI	3	81000FI	4	81000SI
Connector Adapters	1	81000AA				

Performance Test for the Agilent 81635A

Page 3 of 3

Model Agilent 81635A Sensor Module

Report No. _____

Date _____

Test No.	Test Description	Min. Spec.	Result	Max. Spec.	Measurement Uncertainty
I	Accuracy Test		[μW]		
	measured at _____ nm (1310nm) Output Power	9.64 μW	_____	10.36 μW	
	measured at _____ nm (1550nm) Output Power	9.64 μW	_____	10.36 μW	
II	Linearity Test	For Calculations you may want to use the appropriate sheet			
	Range	P_{DUT} [dBm]	P_{DUT} [dBm]	Loss [%]	
	+10	+9	_____	_____	< \pm 0.92 %
	+10	+3	_____	_____	< \pm 0.46 %
	0	+3	_____	_____	< \pm 0.46 %
	0	-7	_____	_____	< \pm 0.46 %
	-10	-7	_____	_____	< \pm 0.46 %
	-10	-17	_____	_____	< \pm 0.46 %
	-20*	-17*	Reference	0.0	< \pm 0.46 %
	-20	-27	_____	_____	< \pm 0.46 %
	-30	-27	_____	_____	< \pm 0.46 %
	-30	-37	_____	_____	< \pm 0.47 %
	-40	-37	_____	_____	< \pm 0.47 %
	-40	-47	_____	_____	< \pm 0.56 %
	-50	-47	_____	_____	< \pm 0.56 %
	-50	-57	_____	_____	< \pm 1.46 %
III	Noise Test		[pW]		
			_____		< 20 pW
IV	Return Loss Test		[dB]		
		40 dB <	_____		

Performance Test for the Agilent 81636B

Page 1 of 3

Model	Agilent 81636B Sensor Module_____	Date	_____
Serial No.	_____	Ambient Temperature	_____ °C
Options	_____	Relative Humidity	_____ %
Firmware Rev.	_____	Line Frequency	_____ Hz

Test Facility	_____	Customer	_____
Performed by	_____	Report No	_____

Special Notes

Performance Test for the Agilent 81636B

Test Equipment Used

Page 2 of 3

	Description	Model No.	Trace No
1a1	Lightwave Multimeter (Std.)	Agilent 8163A/B	_____
1a2	Lightwave Multimeter (DUT)	Agilent 8163A/B	_____
1b	TLS Mainframe	Agilent 8164A/B	_____
2	CW Laser Source	Agilent 81657A	_____
3a	Opt. Head Interface Module	Agilent 81618A	_____
3b	Optical Head, Reference	Agilent 81624B	_____
4	Sensor Module	Agilent 81634B	_____
5a	Optical Attenuator	Agilent 8156A #221	_____
5b	Optical Attenuator	Agilent 8156A #101	_____
6	Return Loss Module	Agilent 81613A	_____
7	_____	_____	_____
8	_____	_____	_____
9	_____	_____	_____
10	_____	_____	_____

Accessories	#	Product	#	Product	#	Product
Singlemode Fibers	2	81101AC	1	81113SC	3	81113PC
Connector Interfaces	4	81000AI	3	81000FI	4	81000SI
Connector Adapters	1	81000AA				

Performance Test for the Agilent 81636B

Page 3 of 3

Model Agilent 81636B Sensor Module

Report No. _____

Date _____

		Min.		Max.	Measurement
Test No.	Test Description	Spec.	Result	Spec.	Uncertainty

I Accuracy Test

[μW]

measured at _____ nm
(1310nm) Output Power

9.64 μW _____

10.36 μW

measured at _____ nm
(1550nm) Output Power

9.64 μW _____

10.36 μW

II Linearity Test

For Calculations you may want to use the appropriate sheet

Range	P _{DUT} [dBm]	P _{DUT} [dBm]	Loss [%]	
+10	+9	_____	_____	< \pm 0.92 %
+10	+3	_____	_____	< \pm 0.46 %
0	+3	_____	_____	< \pm 0.46 %
0	-7	_____	_____	< \pm 0.46 %
-10	-7	_____	_____	< \pm 0.46 %
-10	-17	_____	_____	< \pm 0.46 %
-20*	-17*	Reference	0.0	< \pm 0.46 %
-20	-27	_____	_____	< \pm 0.46 %
-30	-27	_____	_____	< \pm 0.46 %
-30	-37	_____	_____	< \pm 0.47 %
-40	-37	_____	_____	< \pm 0.47 %
-40	-47	_____	_____	< \pm 0.56 %
-50	-47	_____	_____	< \pm 0.56 %
-50	-57	_____	_____	< \pm 1.46 %

III Noise Test

[pW]

< 20 pW

IV Return Loss Test

[dB]

40 dB < _____

Calculation Sheet for Linearity Measurement (81634B, 81635A, 81636B)

Your Entries		Conversion [dBm] → [mW]		Calculation as given		Calculation as given			
n	REF Power [dBm]	DUT Power [dBm]	Ref / R [mW]	DUT / D [mW]	Relation1 / A	Relation2 / B	Non-Linearity = $A_n * B_n (NL_{n±1} + 1) - 1$ [%]		
1									
2									
3									
4					$= R_{n+1} / R_n$	$= D_n / D_{n+1}$			
5									
6									
7									
8									
9									
10									
10							Reference Level		0.00
11							$= R_n / R_{n+1}$	$= D_n / D_{n-1}$	
12									
13									
14									
15									
16									
17									
18									
19									
20									

Calculation Sheet for Linearity Measurement (81630B)

n	Your Entries		Conversion [dBm] → [mW]		Calculation as given			Calculation as given	
	REF Power [dBm]	DUT Power [dBm]	Ref / R [mW]	DUT / D [mW]	Relation1 / A		Relation2 / B	Non-Linearity = $A_n * B_n (NL_{n±1} + 1) - 1$ [%]	
0									
1									
2									
3									
4						= R_{n+1}/R_n	= D_n/D_{n+1}		
5									
6									
7									
8									
9									
10					Reference Level			0.00	
11									
12									
13									
14						= R_n/R_{n+1}	= D_n/D_{n-1}		
15									
16									
17									

5

Cleaning Instructions

The following Cleaning Instructions contain some general safety precautions, which must be observed during all phases of cleaning. Consult your specific optical device manuals or guides for full information on safety matters.

Please try, whenever possible, to use physically contacting connectors, and dry connections. Clean the connectors, interfaces, and bushings carefully after use.

If you are unsure of the correct cleaning procedure for your optical device, we recommend that you first try cleaning a dummy or test device.

Agilent Technologies assume no liability for the customer's failure to comply with these requirements.

Cleaning Instructions for this Instrument

The Cleaning Instructions apply to a number of different types of Optical Equipment. If you must clean the Agilent 81630BN/81634B Power Sensor Modules, please refer the module to the skilled personnel of Agilent's service team. "How to clean instruments with a recessed lens interface" on page 91 is relevant to all other Power Sensor modules.

Safety Precautions

Please follow the following safety rules:

- Do not remove instrument covers when operating.
- Ensure that the instrument is switched off throughout the cleaning procedures.
- Use of controls or adjustments or performance of procedures other than those specified may result in hazardous radiation exposure.
- Make sure that you disable all sources when you are cleaning any optical interfaces.
- Under no circumstances look into the end of an optical device attached to optical outputs when the device is operational. The laser radiation is not visible to the human eye, but it can seriously damage your eyesight.
- To prevent electrical shock, disconnect the instrument from the mains before cleaning. Use a dry cloth, or one slightly dampened with water, to clean the external case parts. Do not attempt to clean internally.
- Do not install parts or perform any unauthorized modification to optical devices.
- Refer servicing only to qualified and authorized personnel.

Why is it important to clean optical devices ?

In transmission links optical fiber cores are about $9\ \mu\text{m}$ (0.00035") in diameter. Dust and other particles, however, can range from tenths to hundredths of microns in diameter. Their comparative size means that they can cover a part of the end of a fiber core, and as a result will reduce the performance of your system.

Furthermore, the power density may burn dust into the fiber and cause additional damage (for example, 0 dBm optical power in a single mode fiber causes a power density of approximately 16 million W/m^2). If this happens, measurements become inaccurate and non-repeatable.

Cleaning is, therefore, an essential yet difficult task. Unfortunately, when comparing most published cleaning recommendations, you will discover that they contain several inconsistencies. In this section, we want to suggest ways to help you clean your various optical devices, and thus significantly improve the accuracy and repeatability of your lightwave measurements.

What do I need for proper cleaning?

Some Standard Cleaning Equipment is necessary for cleaning your instrument. For certain cleaning procedures, you may also require certain Additional Cleaning Equipment.

Standard Cleaning Equipment

Before you can start your cleaning procedure you need the following standard equipment:

- Dust and shutter caps
- Isopropyl alcohol
- Cotton swabs
- Soft tissues
- Pipe cleaner
- Compressed air

Dust and shutter caps

All of Agilent Technologies' lightwave instruments are delivered with either laser shutter caps or dust caps on the lightwave adapter. Any cables come with covers to protect the cable ends from damage or contamination.

We suggest these protected coverings should be kept on the equipment at all times, except when your optical device is in use. Be careful when replacing dust caps after use. Do not press the bottom of the cap onto the fiber too hard, as any dust in the cap can scratch or pollute your fiber surface.

If you need further dust caps, please contact your nearest Agilent Technologies sales office.

Isopropyl alcohol

This solvent is usually available from any local pharmaceutical supplier or chemist's shop.

If you use isopropyl alcohol to clean your optical device, do not immediately dry the surface with compressed air (except when you are cleaning very sensitive optical devices). This is because the dust and the dirt is solved and will leave behind filmy deposits after the alcohol is evaporated. You should therefore first remove the alcohol and the dust with a soft tissue, and then use compressed air to blow away any remaining filaments.

If possible avoid using denatured alcohol containing additives. Instead, apply alcohol used for medical purposes.

Never try to drink this alcohol, as it may seriously damage your health.

Do not use any other solvents, as some may damage plastic materials and claddings. Acetone, for example, will dissolve the epoxy used with fiber optic connectors. To avoid damage, only use isopropyl alcohol.

Cotton swabs

We recommend that you use swabs such as Q-tips or other cotton swabs normally available from local distributors of medical and hygiene products (for example, a supermarket or a chemist's shop). You may be able to obtain various sizes of swab. If this is the case, select the smallest size for your smallest devices.

Ensure that you use natural cotton swabs. Foam swabs will often leave behind filmy deposits after cleaning.

Use care when cleaning, and avoid pressing too hard onto your optical device with the swab. Too much pressure may scratch the surface, and could cause your device to become misaligned. It is advisable to rub gently over the surface using only a small circular movement.

Swabs should be used straight out of the packet, and never used twice. This is because dust and dirt in the atmosphere, or from a first cleaning, may collect on your swab and scratch the surface of your optical device.

Soft tissues

These are available from most stores and distributors of medical and hygiene products such as supermarkets or chemists' shops.

We recommend that you do not use normal cotton tissues, but multi-layered soft tissues made from non-recycled cellulose. Cellulose tissues are very absorbent and softer. Consequently, they will not scratch the surface of your device over time.

Use care when cleaning, and avoid pressing on your optical device with the tissue. Pressing too hard may lead to scratches on the surface or misalignment of your device. Just rub gently over the surface using a small circular movement.

Use only clean, fresh soft tissues and never apply them twice. Any dust and dirt from the air which collects on your tissue, or which has gathered after initial cleaning, may scratch and pollute your optical device.

Pipe cleaner

Pipe cleaners can be purchased from tobacconists, and come in various shapes and sizes. The most suitable one to select for cleaning purposes has soft bristles, which will not produce scratches.

There are many different kinds of pipe cleaner available from tobacco shops.

The best way to use a pipe cleaner is to push it in and out of the device opening (for example, when cleaning an interface). While you are cleaning, you should slowly rotate the pipe cleaner.

Only use pipe cleaners on connector interfaces or on feed through adapters. Do not use them on optical head adapters, as the center of a pipe cleaner is hard metal and can damage the bottom of the adapter.

Your pipe cleaner should be new when you use it. If it has collected any dust or dirt, this can scratch or contaminate your device.

The tip and center of the pipe cleaner are made of metal. Avoid accidentally pressing these metal parts against the inside of the device, as this can cause scratches.

Compressed air

Compressed air can be purchased from any laboratory supplier.

It is essential that your compressed air is free of dust, water and oil. Only use clean, dry air. If not, this can lead to filmy deposits or scratches on the surface of your connector. This will reduce the performance of your transmission system.

When spraying compressed air, hold the can upright. If the can is held at a slant, propellant could escape and dirty your optical device. First spray into the air, as the initial stream of compressed air could contain some condensation or propellant. Such condensation leaves behind a filmy deposit.

Please be friendly to your environment and use a CFC-free aerosol.

Additional Cleaning Equipment

Some Cleaning Procedures need the following equipment, which is not required to clean each instrument:

- Microscope with a magnification range about 50X up to 300X
- Ultrasonic bath
- Warm water and liquid soap
- Premoistened cleaning wipes
- Polymer film
- Infrared Sensor Card

Microscope with a magnification range about 50X up to 300X

A microscope can be found in most photography stores, or can be obtained through or specialist mail order companies. Special fiber-scopes are available from suppliers of splicing equipment.

Ideally, the light source on your microscope should be very flexible. This will allow you to examine your device closely and from different angles.

A microscope helps you to estimate the type and degree of dirt on your device. You can use a microscope to choose an appropriate cleaning method, and then to examine the results. You can also use your microscope to judge whether your optical device (such as a connector) is severely scratched and is, therefore, causing inaccurate measurements.

Ultrasonic bath

Ultrasonic baths are also available from photography or laboratory suppliers or specialist mail order companies.

An ultrasonic bath will gently remove fat and other stubborn dirt from your optical devices. This helps increase the life span of the optical devices.

Only use isopropyl alcohol in your ultrasonic bath, as other solvents may damage.

Warm water and liquid soap

Only use water if you are sure that there is no other way of cleaning your optical device without corrosion or damage. Do not use hot water, as this may cause mechanical stress, which can damage your optical device.

Ensure that your liquid soap has no abrasive properties or perfume in it. You should also avoid normal washing-up liquid, as it can cover your device in an iridescent film after it has been air-dried.

Some lenses and mirrors also have a special coating, which may be sensitive to mechanical stress, or to fat and liquids. For this reason we recommend you do not touch them.

If you are not sure how sensitive your device is to cleaning, please contact the manufacturer or your sales distributor.

Premoistened cleaning wipes

Use pre-moistened cleaning wipes as described in each individual cleaning procedure. Cleaning wipes may be used in every instance where a moistened soft tissue or cotton swab is applied.

Polymer film

Polymer film is available from laboratory suppliers or specialist mail order companies.

Using polymer film is a gentle method of cleaning extremely sensitive devices, such as reference reflectors and mirrors.

Infrared Sensor Card

Infrared sensor cards are available from laboratory suppliers or specialist mail order companies.

With this card you are able to control the shape of laser light emitted. The invisible laser beam is projected onto the sensor card, then becomes visible to the normal eye as a round spot.

Take care never to look into the end of a fiber or any other optical component, when they are in use. This is because the laser can seriously damage your eyes.

Preserving Connectors

Listed below are some hints on how best to keep your connectors in the best possible condition.

Making Connections

Before you make any connection you must ensure that all cables and connectors are clean. If they are dirty, use the appropriate cleaning procedure.

When inserting the ferrule of a patchcord into a connector or an adapter, make sure that the fiber end does not touch the outside of the mating connector or adapter. Otherwise you will rub the fiber end against an unsuitable surface, producing scratches and dirt deposits on the surface of your fiber.

Dust Caps and Shutter Caps

Be careful when replacing dust caps after use. Do not press the bottom of the cap onto the fiber as any dust in the cap can scratch or dirty your fiber surface.

When you have finished cleaning, put the dust cap back on, or close the shutter cap if the equipment is not going to be used immediately.

Keep the caps on the equipment always when it is not in use.

All of Agilent Technologies' lightwave instruments and accessories are shipped with either laser shutter caps or dust caps. If you need additional or replacement dust caps, contact your nearest Agilent Technologies Sales/Service Office.

Immersion Oil and Other Index Matching Compounds

Where it is possible, do not use immersion oil or other index matching compounds with your device. They are liable to impair and dirty the surface of the device. In addition, the characteristics of your device can be changed and your measurement results affected.

Cleaning Instrument Housings

Use a dry and very soft cotton tissue to clean the instrument housing and the keypad. Do not open the instruments as there is a danger of electric shock, or electrostatic discharge. Opening the instrument can cause damage to sensitive components, and in addition your warranty will be voided.

Which Cleaning Procedure should I use ?

Light dirt

If you just want to clean away light dirt, observe the following procedure for all devices:

- Use compressed air to blow away large particles.
- Clean the device with a dry cotton swab.
- Use compressed air to blow away any remaining filament left by the swab.

Heavy dirt

If the above procedure is not enough to clean your instrument, follow one of the procedures below. Please consult "*Cleaning Instructions for this Instrument*" on page 75 for the procedure relevant for this instrument.

If you are unsure of how sensitive your device is to cleaning, please contact the manufacturer or your sales distributor

How to clean connectors

Cleaning connectors is difficult as the core diameter of a single-mode fiber is only about 9 μm . This generally means you cannot see streaks or scratches on the surface. To be certain of the condition of the surface of your connector and to check it after cleaning, you need a microscope.

In the case of scratches, or of dust that has been burnt onto the surface of the connector, you may have no option but to polish the connector. This depends on the degree of dirtiness, or the depth of the scratches. This is a difficult procedure and should only be performed by skilled personal, and as a last resort as it wears out your connector.

WARNING

Never look into the end of an optical cable that is connected to an active source.

To assess the projection of the emitted light beam you can use an infrared sensor card. Hold the card approximately 5 cm from the output of the connector. The invisible emitted light is project onto the card and becomes visible as a small circular spot.

Preferred Procedure

Use the following procedure on most occasions.

- 1 Clean the connector by rubbing a new, dry cotton-swab over the surface using a small circular movement.
- 2 Blow away any remaining lint with compressed air.

Procedure for Stubborn Dirt

Use this procedure particularly when there is greasy dirt on the connector:

- 1 Moisten a new cotton-swab with isopropyl alcohol.
- 2 Clean the connector by rubbing the cotton-swab over the surface using a small circular movement.
- 3 Take a new, dry soft-tissue and remove the alcohol, dissolved sediment and dust, by rubbing gently over the surface using a small circular movement.
- 4 Blow away any remaining lint with compressed air.

An Alternative Procedure

A better, more gentle, but more expensive cleaning procedure is to use an ultrasonic bath with isopropyl alcohol.

- 1** Hold the tip of the connector in the bath for at least three minutes.
- 2** Take a new, dry soft-tissue and remove the alcohol, dissolved sediment and dust, by rubbing gently over the surface using a small circular movement.
- 3** Blow away any remaining lint with compressed air.

How to clean connector interfaces

CAUTION

Be careful when using pipe-cleaners, as the core and the bristles of the pipe-cleaner are hard and can damage the interface.

Do not use pipe-cleaners on optical head adapters, as the hard core of normal pipe cleaners can damage the bottom of an adapter.

Preferred Procedure

Use the following procedure on most occasions.

- 1 Clean the interface by pushing and pulling a new, dry pipe-cleaner into the opening. Rotate the pipe-cleaner slowly as you do this.
- 2 Then clean the interface by rubbing a new, dry cotton-swab over the surface using a small circular movement.
- 3 Blow away any remaining lint with compressed air.

Procedure for Stubborn Dirt

Use this procedure particularly when there is greasy dirt on the interface:

- 1 Moisten a new pipe-cleaner with isopropyl alcohol.
- 2 Clean the interface by pushing and pulling the pipe-cleaner into the opening. Rotate the pipe-cleaner slowly as you do this.
- 3 Moisten a new cotton-swab with isopropyl alcohol.
- 4 Clean the interface by rubbing the cotton-swab over the surface using a small circular movement.
- 5 Using a new, dry pipe-cleaner, and a new, dry cotton-swab remove the alcohol, any dissolved sediment and dust.
- 6 Blow away any remaining lint with compressed air.

How to clean bare fiber adapters

Bare fiber adapters are difficult to clean. Protect from dust unless they are in use.

CAUTION

Never use any kind of solvent when cleaning a bare fiber adapter as solvents can damage the foam inside some adapters.

They can deposit dissolved dirt in the groove, which can then dirty the surface of an inserted fiber.

Preferred Procedure

Use the following procedure on most occasions.

- 1 Blow away any dust or dirt with compressed air.

Procedure for Stubborn Dirt

Use this procedure particularly when there is greasy dirt on the adapter:

- 1 Clean the adapter by pushing and pulling a new, dry pipe-cleaner into the opening. Rotate the pipe-cleaner slowly as you do this.

CAUTION

Be careful when using pipe-cleaners, as the core and the bristles of the pipe-cleaner are hard and can damage the adapter.

- 2 Clean the adapter by rubbing a new, dry cotton-swab over the surface using a small circular movement.
- 3 Blow away any remaining lint with compressed air.

How to clean lenses

Some lenses have special coatings that are sensitive to solvents, grease, liquid and mechanical abrasion. Take extra care when cleaning lenses with these coatings.

Lens assemblies consisting of several lenses are not normally sealed. Therefore, use as little alcohol as possible, as it can get between the lenses and in doing so can change the properties of projection.

Preferred Procedure

Use the following procedure on most occasions.

- 1 Clean the lens by rubbing a new, dry cotton-swab over the surface using a small circular movement.
- 2 Blow away any remaining lint with compressed air.

Procedure for Stubborn Dirt

Use this procedure particularly when there is greasy dirt on the lens:

- 1 Moisten a new cotton-swab with isopropyl alcohol.
- 2 Clean the lens by rubbing the cotton-swab over the surface using a small circular movement.
- 3 Using a new, dry cotton-swab remove the alcohol, any dissolved sediment and dust.
- 4 Blow away any remaining lint with compressed air.

How to clean instruments with a fixed connector interface

You should only clean instruments with a fixed connector interface when it is absolutely necessary. This is because it is difficult to remove any used alcohol or filaments from the input of the optical block.

It is important, therefore, to keep dust caps on the equipment at all times, except when your optical device is in use.

If you do discover filaments or particles, the only way to clean a fixed connector interface and the input of the optical block is to use compressed air.

If there are fluids or fat in the connector, please refer the instrument to the skilled personnel of Agilent's service team.

CAUTION

Only use clean, dry compressed air. Make sure that the air is free of dust, water, and oil. If the air that you use is not clean and dry, this can lead to filmy deposits or scratches on the surface of your connector interface. This will degrade the performance of your transmission system.

Never try to open the instrument and clean the optical block by yourself, because it is easy to scratch optical components, and cause them to be misaligned.

How to clean instruments with a recessed lens interface

WARNING

For instruments with a deeply recessed lens interface (for example the Agilent 81634B Power Sensors) do NOT follow this procedure. Alcohol and compressed air could damage your lens even further.

Keep your dust and shutter caps on, when your instrument is not in use. This should prevent it from getting too dirty. If you must clean such instruments, please refer the instrument to the skilled personnel of Agilent's service team.

Preferred Procedure

Use the following procedure on most occasions.

- 1 Blow away any dust or dirt with compressed air. If this is not sufficient, then
- 2 Clean the interface by rubbing a new, dry cotton-swab over the surface using a small circular movement.
- 3 Blow away any remaining lint with compressed air.

Procedure for Stubborn Dirt

Use this procedure particularly when there is greasy dirt on the interface, and using the procedure for light dirt is not sufficient. Using isopropyl alcohol should be your last choice for recessed lens interfaces because of the difficulty of cleaning out any dirt that is washed to the edge of the interface:

- 1 Moisten a new cotton-swab with isopropyl alcohol.
- 2 Clean the interface by rubbing the cotton-swab over the surface using a small circular movement.
- 3 Take a new, dry soft-tissue and remove the alcohol, dissolved sediment and dust, by rubbing gently over the surface using a small circular movement.
- 4 Blow away any remaining lint with compressed air.

How to clean optical devices which are sensitive to mechanical stress and pressure

Some optical devices, such as the Agilent 81000BR Reference Reflector, which has a gold plated surface, are very sensitive to mechanical stress or pressure. Do not use cotton-swabs, soft-tissues or other mechanical cleaning tools, as these can scratch or destroy the surface.

Preferred Procedure

Use the following procedure on most occasions.

- 1 Blow away any dust or dirt with compressed air.

Procedure for Stubborn Dirt

To clean devices that are extremely sensitive to mechanical stress or pressure you can also use an optical clean polymer film. This procedure is time-consuming, but you avoid scratching or destroying the surface.

- 1 Put the film on the surface and wait at least 30 minutes to make sure that the film has had enough time to dry.
- 2 Remove the film and any dirt with special adhesive tapes.

Alternative Procedure

For these types of optical devices you can often use an ultrasonic bath with isopropyl alcohol. Only use the ultrasonic bath if you are sure that it won't cause any damage anything to the device.

- 1 Put the device into the bath for at least three minutes.
- 2 Blow away any remaining liquid with compressed air.

If there are any streaks or drying stains on the surface, repeat the cleaning procedure.

Additional Cleaning Information

The following cleaning procedures may be used with other optical equipment:

- How to clean bare fiber ends
- How to clean large area lenses and mirrors

How to clean bare fiber ends

Bare fiber ends are often used for splices or, together with other optical components, to create a parallel beam. The end of a fiber can often be scratched. You make a new cleave. To do this:

- 1 Strip off the cladding.
- 2 Take a new soft-tissue and moisten it with isopropyl alcohol.
- 3 Carefully clean the bare fiber with this tissue.
- 4 Make your cleave and immediately insert the fiber into your bare fiber adapter in order to protect the surface from dirt.

How to clean large area lenses and mirrors

Some mirrors, as those from a monochromator, are very soft and sensitive. Therefore, never touch them and do not use cleaning tools such as compressed air or polymer film.

Some lenses have special coatings that are sensitive to solvents, grease, liquid and mechanical abrasion. Take extra care when cleaning lenses with these coatings.

Lens assemblies consisting of several lenses are not normally sealed. Therefore, use as little liquid as possible, as it can get between the lenses and in doing so can change the properties of projection.

Preferred Procedure

Use the following procedure on most occasions.

- 1 Blow away any dust or dirt with compressed air.

Procedure for Stubborn Dirt

Use this procedure particularly when there is greasy dirt on the lens:

CAUTION

Only use water if you are sure that your device does not corrode. Do not use hot water as this can lead to mechanical stress, which can damage your device.

Make sure that your liquid soap has no abrasive properties or perfume in it, because they can scratch and damage your device. Do not use normal washing-up liquid as sometimes an iridescent film remains.

-
- 1 Moisten the lens or the mirror with water.
 - 2 Put a little liquid soap on the surface and gently spread the liquid over the whole area.
 - 3 Wash off the emulsion with water, being careful to remove it all, as any remaining streaks can impair measurement accuracy.
 - 4 Take a new, dry soft-tissue and remove the water, by rubbing gently over the surface using a small circular movement.
 - 5 Blow away remaining lint with compressed air.

Alternative Procedure A

To clean lenses that are extremely sensitive to mechanical stress or pressure you can also use an optical clean polymer film. This procedure is time-consuming, but you avoid scratching or destroying the surface.

- 1 Put the film on the surface and wait at least 30 minutes to make sure that the film has had enough time to dry.
- 2 Remove the film and any dirt with special adhesive tapes.

Alternative Procedure B

If your lens is sensitive to water then:

- 1 Moisten the lens or the mirror with isopropyl alcohol.
- 2 Take a new, dry soft-tissue and remove the alcohol, dissolved sediment and dust, by rubbing gently over the surface using a small circular movement.
- 3 Blow away remaining lint with compressed air.

Other Cleaning Hints

Selecting the correct cleaning method is an important element in maintaining your equipment and saving you time and money. This Appendix highlights the main cleaning methods, but cannot address every individual circumstance.

This section contain some additional hints which we hope will help you further. For further information, please contact your local Agilent Technologies representative.

Making the connection

Before you make any connection you must ensure that all lightwave cables and connectors are clean. If not, then use appropriate the cleaning methods.

When you insert the ferrule of a patchcord into a connector or an adapter, ensure that the fiber end does not touch the outside of the mating connector or adapter. Otherwise, the fiber end will rub up against something which could scratch it and leave deposits.

Lens cleaning papers

Note that some special lens cleaning papers are not suitable for cleaning optical devices like connectors, interfaces, lenses, mirrors and so on. To be absolutely certain that a cleaning paper is applicable, please ask the salesperson or the manufacturer.

Immersion oil and other index matching compounds

Do not use immersion oil or other index matching compounds with optical sensors equipped with recessed lenses. They are liable to dirty the detector and impair its performance. They may also alter the property of depiction of your optical device, thus rendering your measurements inaccurate.

Cleaning the housing and the mainframe

When cleaning either the mainframe or the housing of your instrument, only use a dry and very soft cotton tissue on the surfaces and the numeric pad.

Never open the instruments as they can be damaged. Opening the instruments puts you in danger of receiving an electrical shock from your device, and renders your warranty void.

Index

A

Accessories 15
 Accuracy Test 37
 Accuracy test 37
 Analog output 13
 specification 31
 Averaging time 20

C

Calculation sheet
 Linearity measurement 72
 Connector interface 13
 Connector interfaces 17

E

Example calculations 46

F

Front panel 12

L

Linearity 21
 Linearity Test 39
 Linearity test 39
 Linewidth 21

N

Noise 22
 Noise Test 48
 Noise test 48

O

Optional features 16

P

Performance Tests 33
 Agilent 81632A 56, 66
 Agilent 81635A 63
 performance tests 36
 Power range 22
 Power Sensor module
 Performance tests 33

R

Reference conditions 22
 Relative Uncertainty due to Interference 53
 Return Loss 9
 Return loss 23
 Return Loss Test 49
 Return loss test 49

S

Safety 10
 Specifications 19
 81630B 29
 81634B 25
 81635A 25
 81636B 27
 Spectral ripple 23

T

Test equipment 34
 Test record sheets 56
 Total uncertainty 24

U

Uncertainty due to interference test 51
 Uncertainty due to polarization test 51

W

Wavelength range 24

© Agilent Technologies 2002 - 2005

Printed in Germany July 2005
Third edition, July 2005



81635-90B12